



CONCEPT

'THE CORE COLLECTION'
Display Solutions



LIVE LIFE WITH FLUORESCENTS

OUR NEW LARGE FORMAT DIGITAL TEXTILE PRESS IS CAPABLE OF PRODUCING A WIDE RANGE OF CUSTOMISED, COMPLEX AND STRIKING PRINT DESIGNS USING OUR SPECIAL FLUORESCENT INKS.

We specialise in: Fabric Display Stands, LED Fabric Light Boxes, Wall & Freestanding, Feather & Teardrop Flags, Custom Printed Flags, Deck Chairs, Directors Chairs, Bean Bags, Cubes, Tablecloths, Fabric Hanging Displays.



CONTENTS

Aluminium Feather Flags	04
Aluminium Tear Drop Flags	06
Aluminium Rectangle Flags	08
Fibreglass Feather Flags	10
Fibreglass Teardrop Flags	12
Giant Rhino Flag	14
Backpack/Atlas Ad Flag	15
Custom Printed Flags/Promotional Bunting	16
Printed Tablecloths	17
Printed Furniture	18
Printed Gazebos	20
Printed Tents	22
Printed Parasols	23
Monsoon/Pop Out Banners	24
Café Barriers	25
Fence & Event Branding	26
Roller Banners	27
Soft Touch	37
Pop Up Displays	46
Curved Banner/Fabric Wall	49
Aero Plus	50
Twist Banners	51
Stealth Banners	53
Shell Schemes	55
Fabric Tension Systems	56
Counters	58
A-Boards	61
Literature Holders	65
Folding Panel Kits	68
Leaflet Holders	69
Snap Frames	71
Display Boards	74
Selfie Frames	82
Business Cards	83
Litho/Digital Printing	84

FF ALUMINIUM FEATHER FLAGS

Ideal branding solution for outdoor and indoor events, exhibitions and retail outlets.

- Highly visible branding solution
- Choose from 7 base options
- Reinforced, yet lightweight aluminium pole is available in 4 heights: 2.3m, 3.2m 4.1m & 5.1m
- Printed on 110gsm knitted polyester flag material
- Image reads correctly one side, with reverse as show through
- Indoor or outdoor use
- All products individually packaged in cartons



FOLLOW THESE EASY STEPS

- Choose a pole size
- Choose a base (7 options)
- Choose a carry bag (if required)



MIRROR IMAGE REVERSE



DOUBLE SIDED FLAG

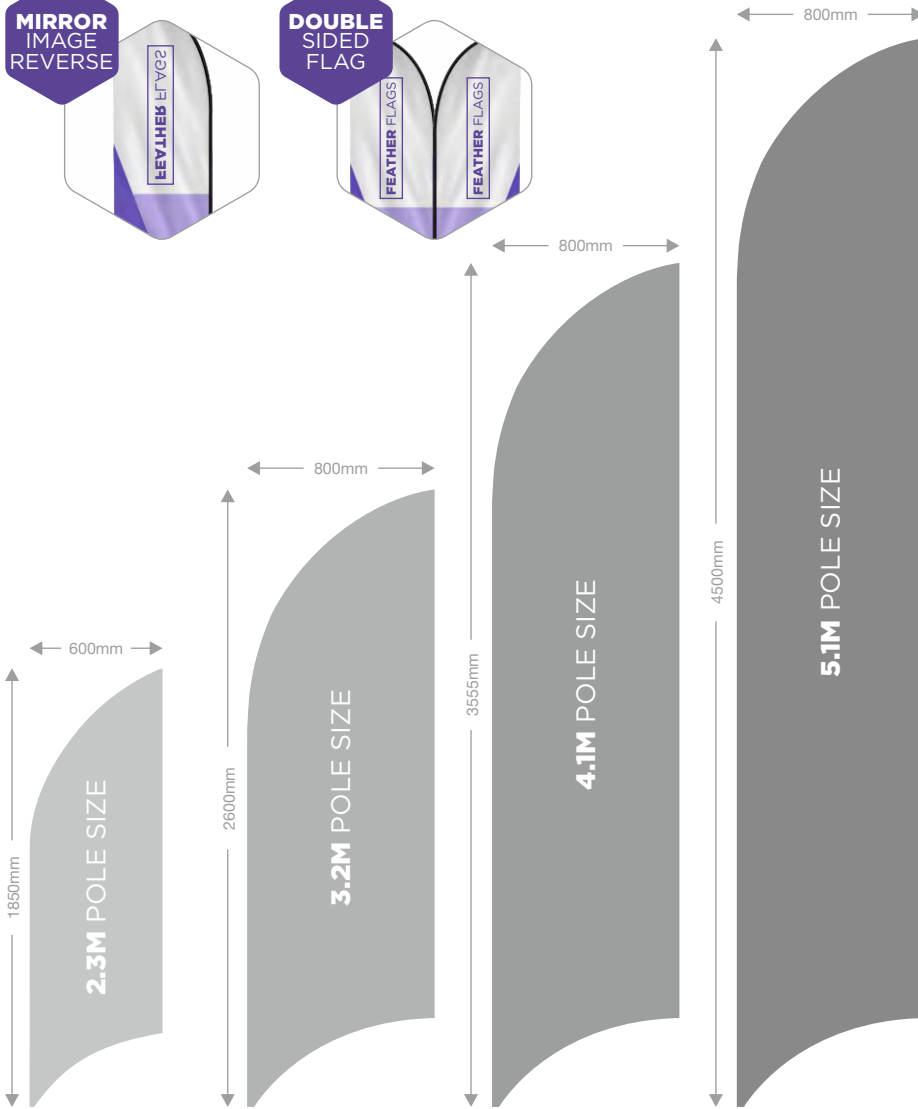

CHOOSE SLEEVE COLOUR



CHOOSE YOUR FLAG BASE



All sizes are approx
SMALL 2.3m
 Code: RFF0230

MEDIUM 3.2m
 Code: RFF0320

LARGE 4.1m
 Code: RFF0410

EXTRA LARGE 5.1m
 Code: RFF0510

FB ALUMINIUM FEATHER FLAGS BUNDLE KITS

01 2.3M BUNDLE 01

- 1 x 2.3m feather flag and pole kit
- 1 x Ground spike base
- 1 x Carry case

SINGLE SIDED FLAG



BUNDLE 01
Code: AFB23S

02 3.2M BUNDLE 02

- 1 x 3.2m Feather flag and pole kit
- 1 x Small water base
- 1 x Carry case

SINGLE SIDED FLAG



BUNDLE 02
Code: AFB32B

01 4.1M BUNDLE 03

- 1 x 4.1m Feather flag and pole kit
- 1 x Large water base
- 1 x Carry case

SINGLE SIDED FLAG



BUNDLE 03
Code: AFB41B

02 5.1M BUNDLE 04

- 1 x 5.1m Feather flag and pole kit
- 1 x Ground spike base
- 1 x Carry case

SINGLE SIDED FLAG



BUNDLE 04
Code: AFB51S

FB FLAG BASES



Ground Spike
Size: 600mm length. Steel with Chrome plate for soft ground - grass, sand, and snow. Weight 1.4kg.
Code: RBGRSPK



Cross Base
Size: 620mm x 620mm. Made from Steel with powder coat and supplied with ground pegs. Weight 2kg.
Suitable for up to 3.2m pole kits with Weighting ring.
Code: RBCRSBA



Weighting Ring
Round Water Bag to use with Cross Base, adds more stability when filled with water (an extra 5kg). Size: Dia 520mm. Made from PVC..
Code: RBWATBA



Car Wheel Base
Powder Coated Steel. Size: 600mm x 220mm. Weight: 4.5kg.
Code: RBWHEBA



Rhino Small Water/Sand Base
Size: 430mm x 430mm x 140mm (Height). Approx 25kg water or 38kg sand.
Suitable for up to 3.2m pole kits.
Code: RBSWA20



Rhino Large Water/Sand Base
Size: 500mm (dia) x 185mm (Height). Approx 33kg water or 50kg Sand.
Code: RBLWA30



Screw Spike Base
Made from strong PVC Plastic soft ground - grass, sand, and snow. Light Weight at 0.4kg. Collapsible handles to help with installation and removal. 24cm screw submerged underground for a strong fixture
Code: RBSCSPK



Metal Steel Plate Base
Secure your base with our powder coated steel flatplate perfect for flags up to 3.2m in height.
Code: RBFPLT400

TD ALUMINIUM TEAR DROP FLAGS

Ideal branding solution for outdoor and indoor events, exhibitions and retail outlets.

- Highly visible branding solution
- Choose from 7 base options
- Reinforced, yet lightweight aluminium pole is available in 3 heights: 2m, 3m, 4m
- Printed on 110gsm knitted polyester flag material
Image reads correctly one side, with reverse as show through
Indoor or outdoor use
All products individually packaged in cartons



FOLLOW THESE EASY STEPS

- Choose a pole size and shape
- Choose a base (7 options, see next page)
- Choose a carry bag (if required)



MIRROR IMAGE REVERSE



DOUBLE SIDED FLAG

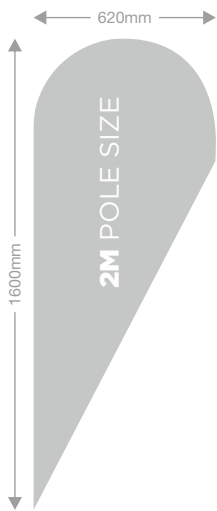

All sizes are approx

SMALL 2m

Code: RTF0200



MEDIUM 3m

Code: RTF0300

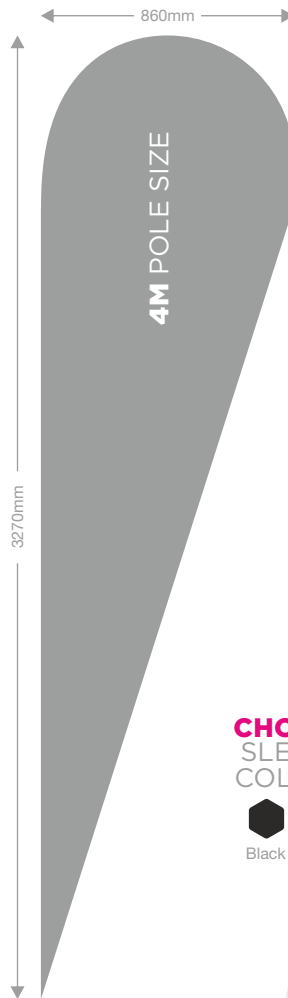

LARGE 4m

Code: RTF0400

CHOOSE SLEEVE COLOUR



CHOOSE YOUR FLAG BASE

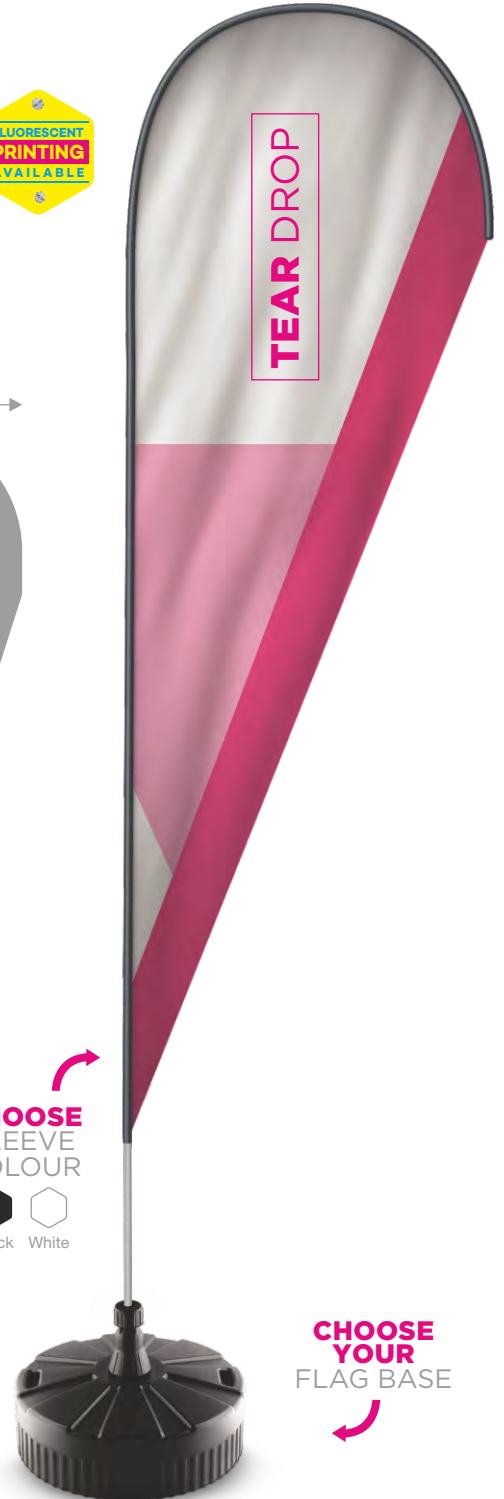

TB TEAR DROP FLAGS BUNDLE KITS

01 2M BUNDLE 01

- 1 x 2m Tear drop flag and pole kit
- 1 x Ground spike base
- 1 x Carry case

SINGLE SIDED FLAG



BUNDLE 01

Code: TDFB2S

02 3M BUNDLE 02

- 1 x 3m Tear drop flag and pole kit
- 1 x Small water base
- 1 x Carry case

SINGLE SIDED FLAG



BUNDLE 02

Code: TDFB3B

01 4M BUNDLE 03

- 1 x 4m Tear drop flag and pole kit
- 1 x Large water base
- 1 x Carry case

SINGLE SIDED FLAG



BUNDLE 03

Code: TDFB4B

02 4M BUNDLE 04

- 1 x 4m Tear drop flag and pole kit
- 1 x Ground spike base
- 1 x Carry case

SINGLE SIDED FLAG



BUNDLE 04

Code: TDFB4AS

FB FLAG BASES



Ground Spike

Size: 600mm length. Steel with Chrome plate for soft ground - grass, sand, and snow. Weight 1.4kg.

Code: RBGRSPK



Cross Base

Size: 620mm x 620mm. Made from Steel with powder coat and supplied with ground pegs. Weight 2kg. Suitable for up to 3.2m pole kits with Weighting ring.

Code: RBCRSBA



Weighting Ring

Round Water Bag to use with Cross Base, adds more stability when filled with water (an extra 5kg). Size: Dia 520mm. Made from PVC..

Code: RBWATBA



Car Wheel Base

Powder Coated Steel. Size: 600mm x 220mm. Weight: 4.5kg.

Code: RBWHEBA



Rhino Small Water/Sand Base

Size: 430mm x 430mm x 140mm (Height). Approx 25kg water or 38kg sand. Suitable for up to 3.2m pole kits.

Code: RBSWA20



Rhino Large Water/Sand Base

Size: 500mm (dia) x 185mm (Height). Approx 33kg water or 50kg Sand.

Code: RBLWA30



Screw Spike Base

Made from strong PVC Plastic soft ground - grass, sand, and snow. Light Weight at 0.4kg. Collapsible handles to help with installation and removal. 24cm screw submerged underground for a strong fixture

Code: RBSCSPK



Metal Steel Plate Base

Secure your base with our powder coated steel flatplate perfect for flags up to 3.2m in height.

Code: RBFPLT400

RF ALUMINIUM RECTANGLE FLAGS

Ideal branding solution for outdoor and indoor events, exhibitions and retail outlets.

- Highly visible branding solution
- Choose from 7 base options
- Reinforced, yet lightweight aluminium pole is available in 3 heights: 2.5m, 3.5m & 4.5m
- Printed on 110gsm knitted polyester flag material
- Image reads correctly one side, with reverse as show through
- Indoor or outdoor use
- All products individually packaged in cartons

MIRROR IMAGE REVERSE

DOUBLE SIDED FLAG

FOLLOW THESE EASY STEPS

- Choose a pole size
- Choose a base (7 options, see next page)



CHOOSE SLEEVE COLOUR



All sizes are approx

SMALL 2.5m

Code: RRF0250



MEDIUM 3.5m

Code: RRF0350



LARGE 4.5m

Code: RRF0450



CHOOSE YOUR FLAG BASE



RB ALUMINIUM FLAGS BUNDLE KITS

01 2.5M BUNDLE 01

SINGLE SIDED FLAG

- 1 x 2.5m Rectangle flag and pole kit
- 1 x Small water base
- 1 x Carry case



BUNDLE 01

Code: RFFB25



02 2.5M BUNDLE 02

SINGLE SIDED FLAG

- 1 x 2.5m Rectangle flag and pole kit
- 1 x Ground spike base
- 1 x Carry case



BUNDLE 02

Code: RFFB35



03 3.5M BUNDLE 02

SINGLE SIDED FLAG

- 1 x 3.5m Rectangle flag and pole kit
- 1 x Small water base
- 1 x Carry case



BUNDLE 02

Code: RFFB35



04 4.5M BUNDLE 02

SINGLE SIDED FLAG

- 1 x 4.5m Rectangle flag and pole kit
- 1 x Large water base
- 1 x Carry case



BUNDLE 04

Code: RFFB45B



FB FLAG BASES



Ground Spike

Size: 600mm length. Steel with Chrome plate for soft ground - grass, sand, and snow. Weight 1.4kg.

Code: RBGRSPK



Cross Base

Size: 620mm x 620mm. Made from Steel with powder coat and supplied with ground pegs. Weight 2kg. Suitable for up to 3.2m pole kits with Weighting ring.

Code: RBCRSBA



Weighting Ring

Round Water Bag to use with Cross Base, adds more stability when filled with water (an extra 5kg). Size: Dia 520mm. Made from PVC..

Code: RBWATBA



Car Wheel Base

Powder Coated Steel. Size: 600mm x 220mm. Weight: 4.5kg.

Code: RBWHEBA



Rhino Small Water/Sand Base

Size: 430mm x 430mm x 140mm (Height). Approx 25kg water or 38kg sand. Suitable for up to 3.2m pole kits.

Code: RBSWA20



Rhino Large Water/Sand Base

Size: 500mm (dia) x 185mm (Height). Approx 33kg water or 50kg Sand.

Code: RBLWA30



Screw Spike Base

Made from strong PVC Plastic soft ground - grass, sand, and snow. Light Weight at 0.4kg. Collapsible handles to help with installation and removal. 24cm screw submerged underground for a strong fixture

Code: RBSCSPK



Metal Steel Plate Base

Secure your base with our powder coated steel flatplate perfect for flags up to 3.2m in height.

Code: RBFPLT400

DIFFERENT SHAPES AVAILABLE
USING THE SAME POLE

FF 100% FIBREGLASS FEATHER FLAGS

Rhino's 100% fibreglass flag pole is the ultimate flag system you can buy.

- Choose from 8 base options
- Flexible Light weight fibreglass pole system available in 4 heights
- Printed on 110gsm Knitted polyester flag material, single sided with mirror image on reverse.
- Indoor or outdoor use
- Includes drawstring carry bag
- Same fibreglass poles can be used for all shapes



FOLLOW THESE EASY STEPS

- Choose a pole size and shape
- Choose a base (7 options, see next page)



CHOOSE SLEEVE COLOUR

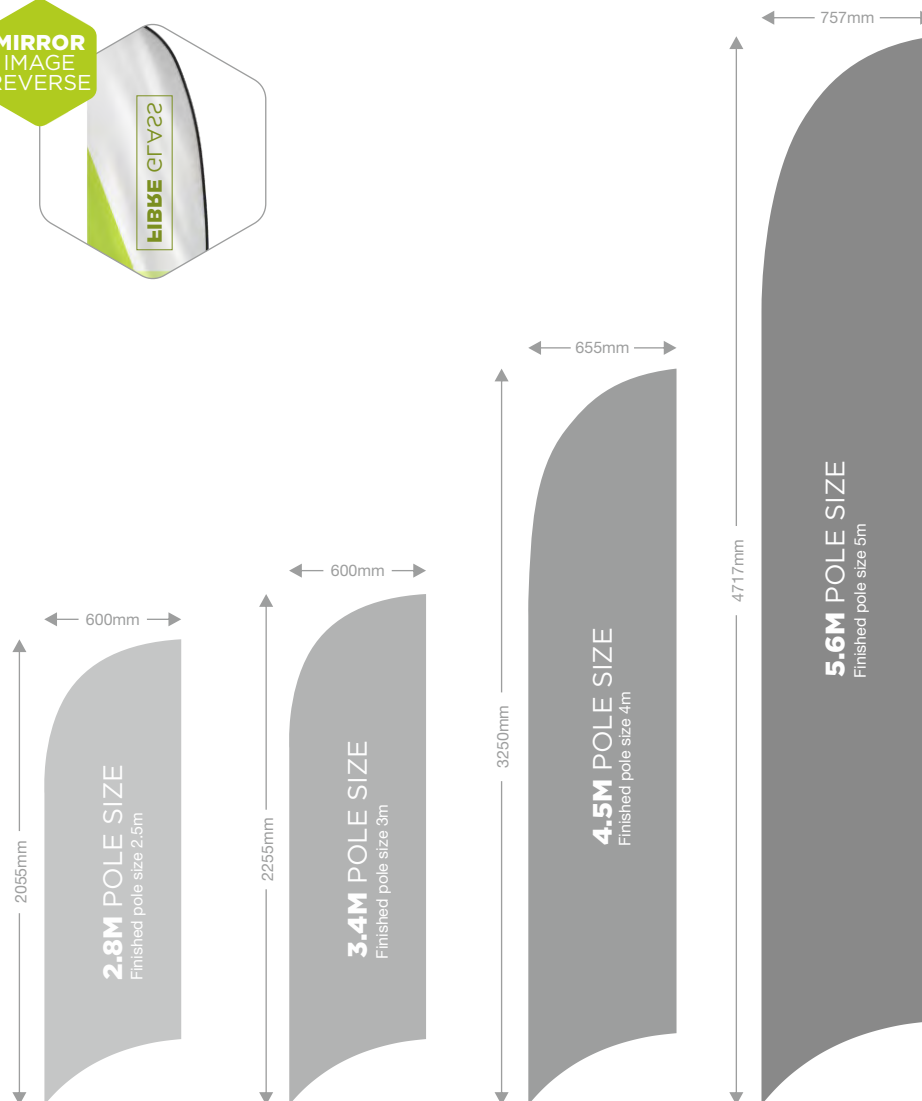

FIBRE GLASS

CHOOSE YOUR FLAG BASE



All flag sizes are approx

SMALL 2.8m Code: RFG0280	MEDIUM 3.4m Code: RFG0340	LARGE 4.5m Code: RFG0450	EXTRA LARGE 5.6m Code: RFG0560
------------------------------------	-------------------------------------	------------------------------------	--

FB 100% FIBREGLASS FLAGS BUNDLE KITS

01 2.8M BUNDLE 01

- 1 x 2.8m feather flag and pole kit
- 1 x Small water base
- 1 x Carry case

SINGLE SIDED FLAG



BUNDLE 01

Code: FGFF28S

02 3.4M BUNDLE 02

- 1 x 3.4m feather flag and pole kit
- 1 x Ground spike base
- 1 x Carry case

SINGLE SIDED FLAG



BUNDLE 02

Code: FGFF34B

03 4.5M BUNDLE 03

- 1 x 4.5m feather flag and pole kit
- 1 x Ground spike base
- 1 x Carry case

SINGLE SIDED FLAG



BUNDLE 03

Code: FGFF45B

04 5.6M BUNDLE 04

- 1 x 5.6m feather flag and pole kit
- 1 x Large water base
- 1 x Carry case

SINGLE SIDED FLAG



BUNDLE 04

Code: FGFF56S

FB FLAG BASES



Ground Spike

Size: 600mm length. Steel with Chrome plate for soft ground - grass, sand, and snow. Weight 1.4kg.

Code: RBGRSPK



Cross Base

Size: 620mm x 620mm. Made from Steel with powder coat and supplied with ground pegs. Weight 2kg. Suitable for up to 3.2m pole kits with Weighting ring.

Code: RBCRSBA



Weighting Ring

Round Water Bag to use with Cross Base, adds more stability when filled with water (an extra 5kg). Size: Dia 520mm. Made from PVC..

Code: RBWATBA



Car Wheel Base

Powder Coated Steel. Size: 600mm x 220mm. Weight: 4.5kg.

Code: RBWHEBA



Rhino Small Water/Sand Base

Size: 430mm x 430mm x 140mm (Height). Approx 25kg water or 38kg sand. Suitable for up to 3.2m pole kits.

Code: RBSWA20



Rhino Large Water/Sand Base

Size: 500mm (dia) x 185mm (Height). Approx 33kg water or 50kg Sand.

Code: RBLWA30



Screw Spike Base

Made from strong PVC Plastic soft ground - grass, sand, and snow. Light Weight at 0.4kg. Collapsible handles to help with installation and removal. 24cm screw submerged underground for a strong fixture

Code: RBSCSPK



Metal Steel Plate Base

Secure your base with our powder coated steel flatplate perfect for flags up to 3.2m in height.

Code: RBFPLT400

FF

100% FIBREGLASS TEARDROP FLAGS

Rhino's 100% fibreglass flag pole is the ultimate flag system you can buy.

- Choose from 8 base options
- Flexible Light weight fibreglass pole system available in 4 heights
- Printed on 110gsm Knitted polyester flag material, single sided with mirror image on reverse.
- Indoor or outdoor use
- Includes drawstring carry bag
- Same fibreglass poles can be used for all shapes

DIFFERENT SHAPES AVAILABLE USING THE SAME POLE



FOLLOW THESE EASY STEPS

- Choose a pole size and shape
- Choose a base (7 options, see next page)



CHOOSE SLEEVE COLOUR

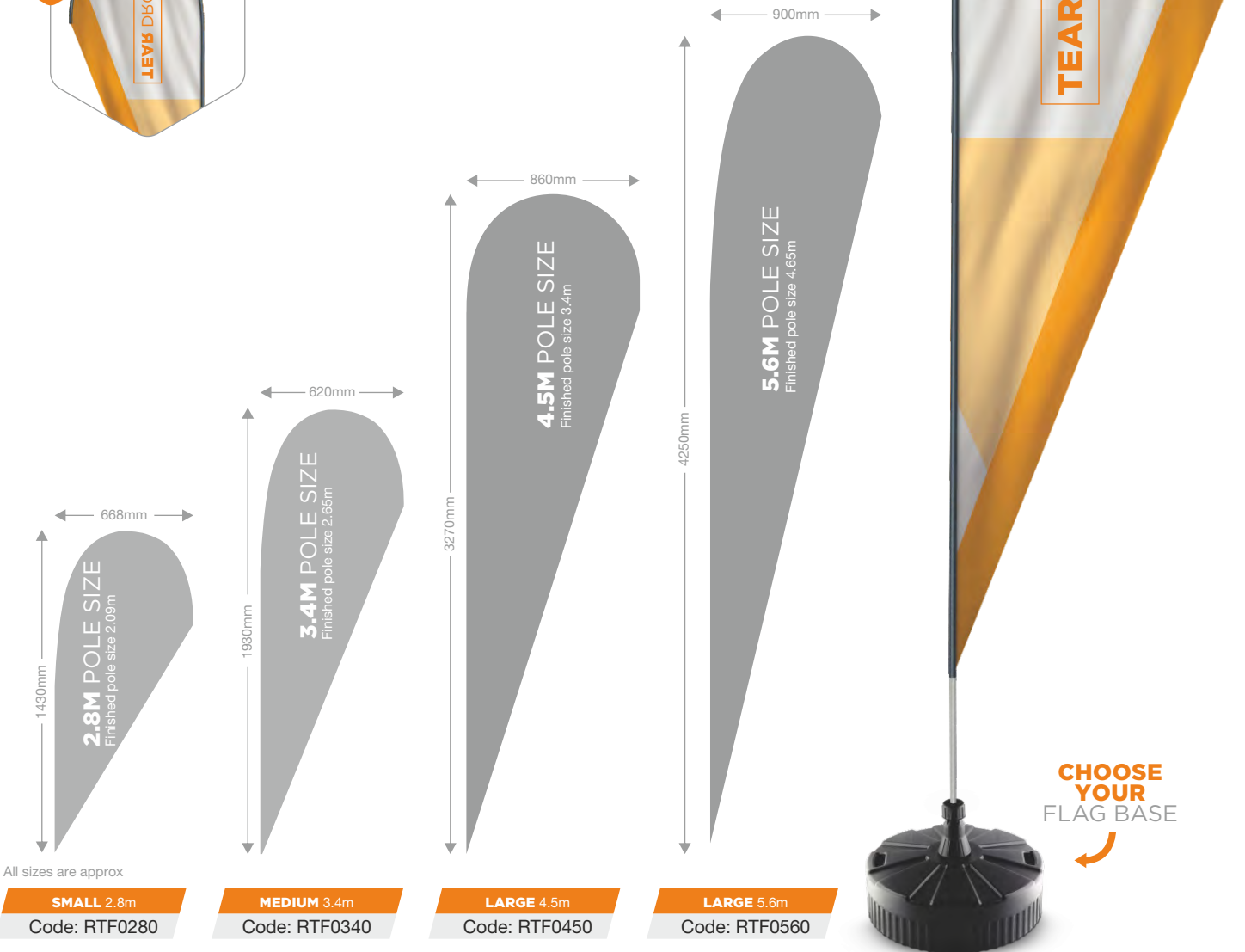

FB 100% FIBREGLASS FLAGS BUNDLE KITS

01 2.8M BUNDLE 01

- 1 x 2.8m feather flag and pole kit
- 1 x Ground spike base
- 1 x Carry case

SINGLE SIDED FLAG



BUNDLE 01

Code: FGTD28S

02 3.4M BUNDLE 02

- 1 x 3.4m feather flag and pole kit
- 1 x Small water base
- 1 x Carry case

SINGLE SIDED FLAG



BUNDLE 01

Code: FGTD34B

03 4.5M BUNDLE 03

- 1 x 4.5m feather flag and pole kit
- 1 x Large water base
- 1 x Carry case

SINGLE SIDED FLAG



BUNDLE 02

Code: FGTD45B

04 5.6 BUNDLE 04

- 1 x 5.6m feather flag and pole kit
- 1 x Ground spike base
- 1 x Carry case

SINGLE SIDED FLAG



BUNDLE 02

Code: FGTD56S

FB FLAG BASES



Ground Spike

Size: 600mm length. Steel with Chrome plate for soft ground - grass, sand, and snow. Weight 1.4kg.

Code: RBGRSPK



Cross Base

Size: 620mm x 620mm. Made from Steel with powder coat and supplied with ground pegs. Weight 2kg. Suitable for up to 3.2m pole kits with Weighting ring.

Code: RBCRSBA



Weighting Ring

Round Water Bag to use with Cross Base, adds more stability when filled with water (an extra 5kg). Size: Dia 520mm. Made from PVC..

Code: RBWATBA



Car Wheel Base

Powder Coated Steel. Size: 600mm x 220mm. Weight: 4.5kg.

Code: RBWHEBA



Rhino Small Water/Sand Base

Size: 430mm x 430mm x 140mm (Height). Approx 25kg water or 38kg sand. Suitable for up to 3.2m pole kits.

Code: RBSWA20



Rhino Large Water/Sand Base

Size: 500mm (dia) x 185mm (Height). Approx 33kg water or 50kg Sand.

Code: RBLWA30



Screw Spike Base

Made from strong PVC Plastic soft ground - grass, sand, and snow. Light Weight at 0.4kg. Collapsible handles to help with installation and removal. 24cm screw submerged underground for a strong fixture

Code: RBSCSPK



Metal Steel Plate Base

Secure your base with our powder coated steel flatplate perfect for flags up to 3.2m in height.

Code: RBFPLT400



GIANT RHINO PORTABLE FLAG



Designed to be lightweight and portable for transportation yet impactful and heavyweight at the event. Simply fill the base with water to add weight and stability and then attach the pole and flag.

- Portable and lightweight for transportation
- Base splits into 4 easy carriage parts
- Telescopic pole
- Easy clip on the flag using eyelets
- Withstands 13-18 mph winds (Beaufort scale 4)
- Flag graphic sizes:
- 1000mm x 3500mm
- Weights/capacity:
- 17.5kg empty, 76kg full (66 litres)
- Reverse side of flag is a mirror image of the front side
- Optional carry bags available £POA
- Includes printed flag

5M GIANT RHINO - MAXI

Code: GR-05



WATER OR SAND FILLED BASE





BACK PACK FLAGS



This is a fantastic way to advertise events and promotions, quick and easy to use this is a very cost effective flag display system. We can supply the whole kit consisting of backpack and banner; the backpacks can be reused for different events. We can supply the banner flag on its own enabling you to advertise different events and promotions.

The system comprises of a quality backpack, sectional flagpole and banner flag. Both sides of the flag banner can be the same or two different designs. There are two styles of banner flag shapes you can choose from Sail (Teardrop) Backpack or Rectangle Backpack.

SAIL (TEARDROP) BACKPACK

Code: BPF01

RECTANGLE BACKPACK

Code: BPF02



Large pocket



Padded shoulder straps



Side view



Carry bag



ATLAS AD FLAG



- Suitable for lightweight flag textile
- Plastic, easy push-fit assembly
- Adjustable height pole
- Black pole and base
- Hollow base for water or sand weighting - 8 litre capacity
- Overall Height 2560mm
- Weight 2.6kg. With water filled base 9.6kg
- Flag size: 550mm (w) x 1800mm (h)
- Indoor or outdoor use

AD FLAG SIZE

Code: ADF500





CUSTOM PRINTED FLAGS



Custom printed flag flags are the most versatile and best value flags on the market in the UK today. Combining top of the range materials and optimum flying weights, these flags last as well as traditional sewn flags but fly much better at lower wind speeds.

Manufactured using flame-retardant 110gsm knitted polyester and fitted with rope and toggle as standard, these flags can be fitted with metal eyelets or a sleeve at no extra charge. Unlike other printers we Colour fix and wash all our outdoor fabric flags before they are dispatched so no colour runs GUARANTEED!

SIZE	CODE
2ft x 3ft single sided	CF02X3
2ft x 3ft double sided	CFD2X3
3ft x 5ft single sided	CF03X5
3ft x 5ft double sided	CFD3X5
4ft x 6ft single sided	CF04X6
4ft x 6ft double sided	CFD4X6
5ft x 8ft single sided	CF05X8
5ft x 8ft double sided	CFD5X8
6ft x 10ft single sided	CF06X10
6ft x 10ft double sided	CFD6X10
8ft x 12ft single sided	CF08X12
8ft x 12ft double sided	CFD8X12



Custom flags used for:

- Promotional Events
- Schools and Colleges
- Sporting Events
- State and National Days
- Personal Use
- Business and Corporations
- Distributor Resale

Custom printed flag specs:

- No minimum required
- Fully custom sized (your choice)
- Inks and dyes UV protected
- Printed with Dye sub
- Single sided or Double
- 110gsm knitted Polyesters



PROMOTIONAL PRINTED BUNTING



Custom printed bunting is versatile and eye-catching product that would add colour to any event especially when printed with your brand logo or image. Pennants can be triangular, rectangular or custom cut to almost any shape to create a professional image. Bunting is used to decorate indoor and outdoor spaces.

- 10m lengths
- 24 printed pennants per length
- Pennant size: approx. 290mm x 200mm
- Material: Knitted Polyester
- For outdoor or indoor use
- Style: Triangular, Rectangular or Custom Pennants
- 3 alternate designs per length inc
- Design shows correctly to one side, and is mirror image to reverse.





PRINTED TABLECLOTHS

DIGITAL PRINTED



Help to promote your company. If you are going to an exhibition or an event where you will be showcasing your company why not consider a promotional printed tablecloth.

Help your company to stand out from the crowd and have a professional finish to your table. We have helped thousands of companies to do this, from large blue chip companies requiring hundreds of printed tablecloths for worldwide usage to small one man outfits, our printed tablecloths can help you to win business and customers. All printed all over the cloth in a range of fabric and colour options so if you need a pantone specific background colour to your cloth or a really intricate design we can provide this for you.

- 210gsm Polyester
- Fire Retardant Coating On Material
- Waterproof DYE inks
- UV stable
- Stitched all around Using 100% Polyester Thread
- Special bespoke finishing available
- Bespoke size tablecloths also available - Quote on request



**BESPOKE
SIZES
AVAILABLE**

**FITTED
STRETCH
FABRIC
TABLECLOTHS
AVAILABLE**

SIZE	CODE
1780mm x 2780mm - approx. (6ft x 9ft) for a 6ft x 2ft table size trestle tables to the floor with a back drop	PTC0609
1780mm x 3660mm - approx. (6ft x 12ft) for a 8ft x 2ft table size trestle table to the floor all round	PTC0612
2000mm x 1000mm for table runners use, easy to fold & carry - runs front to back	PTC2010



FOLDING TABLES

- Polypropylene and metal frame trestle table with folding legs
- Folds in half with carry handles for easy transportation
- Strong and sturdy, can be used for many situations and applications

Total hardware dimensions (approx.):

- Open: 750 (h) x 1830 (w) x 750 (d) mm
- Folded: 920 (h) x 750 (w) x 90 (d) mm



Locking ring



Carry handle for easy transportation

FOLDED TABLE
Code: FT750



CS CUBE SEATS



Made from lightweight polystyrene, offering comfortable seating option. Stylish, modern and easily transportable. Can be supplied with or without textile fabric cover or eco leather cover.

Total hardware dimensions (approx.):

- 450 (h) x 450 (w) x 450 (d) mm

FABRIC	ECO LEATHER
CS450F	CS450EL

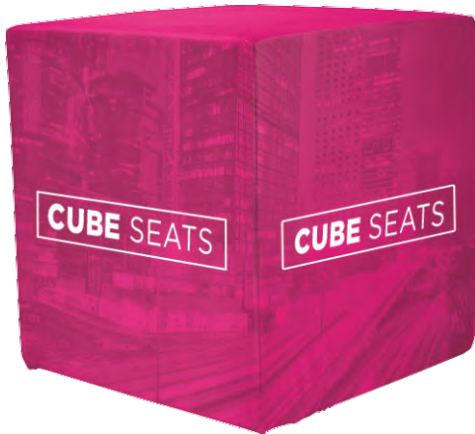

BC BRANDED CUSHIONS



An ideal product for both retail and end user customers, our bespoke printed cushions are available in a wide range of size options, and with multiple fabrics and finishing choices, you can truly create your own unique product.

- Fully customised printing
- Choice of sizes
- Wide fabric choice
- Envelope or Zip fastening
- No minimum order
- Fully washable at 40°C
- Medium temperature iron
- Fully colourfast
- Standard sizes = 45 x 45 cm, 60 x 60 cm, 50 x 30 cm

450MM x 450MM
BC450

600MM x 600MM
BC600

500MM x 300MM
BC500



BB BRANDED BEANBAGS



Our digitally printed beanbags are manufactured from a hard wearing waterproof polyester fabric that gives you the opportunity to have your beanbag printed with your own design, whilst at the same time being an easy care, fully waterproof fabric base, which ensures that the product is not compromised by outdoor use.

- Fully customised printing
- Choice of sizes
- Hardwearing polyester fabric
- Photographic quality prints
- Colour matching available
- No minimum order
- Fully washable at 40°C
- Fully colourfast

70CM x 111CM
BB70
85CM x 111CM
BB85
100cm x 111cm
BB100
130cm x 100cm
BB130
140cm x 140cm
BB140



FC FLUX CHAIR

The flux chair. Our award-winning Dutch design. Looks like a giant envelope; turns into a designer chair. Simple. One craftily cut sheet of sustainable polypropylene; six colours to choose from; zero tools necessary. For extra comfort check out our chair pads below.

- Flux chair can be purchased plain or branded
- Folded height: 770mm x 850mm x 15mm
- Weight: 5KG
- Assembled height 840mm
- Assembled Width: 660mm

FLUX CHAIR
Code: FCP005





DECK CHAIRS



Not just for the beach! For the ultimate in relaxed meetings where better than reclining in your own branded Deck Chair. Perfect for seated audience situations or casual gatherings.

- Folding hardwood frames
- Supplied fully assembled ready to use
- Volume pricing options
- High quality printed canvas with full colour graphics
- Total hardware dimensions (approx):
Folded: 1320 (h) x 560 (l) x 40mm (w)
- Printed area: 940mm x 430mm

DECK CHAIR

DC2015



DIRECTORS CHAIRS



Brand a seating area with our innovative range of chairs and furniture. These super-comfy chairs are smart for your event and create a little wow factor wherever they go.

- Manufactured from FSC certified wood from sustainable sources
- High quality dye printed graphics on the seat and the base
- Corporate branding or photographic reproduction
- Co-ordinate with exhibition branding or interior design
- Removable washable covers
- Total hardware dimensions (approx):
860 x 510mm
- Printed area:
Back rest: 500 x 160mm approx
Seat: 390 x 440mm approx

DIRECTOR CHAIR

DC2016



BG BUILD YOUR OWN GAZEBO

FOLLOW THESE EASY STEPS

- A** Choose your frame size
- B** Choose your printed areas
- C** Choose single or double sided prints
- D** Add optional weights

A	FRAME SIZE	CODE
	2m x 2m	RG2X2
	3m x 3m	RG3X3
	3m x 4.5m	RG3X4.5
	3m x 6m	RG3X6

B	PRINT OPTIONS	SINGLE SIDED	DOUBLE SIDED
	Full wall	FWSS	FWDS
	Half wall	HWSS	HFDS



Frame 40mm x 40mm diameter hexagonal aluminium extrusion



D

Optional 12.5kg weights

RG RHINO GAZEBO PACKAGE DEALS

01 GAZEBO KIT 01

- 3x3m Rhino aluminum frame
- 1x Full colour canopy roof
- 1x Heavy duty wheeled case (gazebo)
- 1x Set of pegs

OTHER
FRAME
SIZES
AVAILABLE

BUNDLE 01

Code: RGB01



02 GAZEBO KIT 02

- 3x3m Rhino aluminum frame
- 1x Full colour canopy roof
- 3x Full single sided printed walls
- 1x Heavy duty wheeled case (gazebo)
- 1x Set of pegs

OTHER
FRAME
SIZES
AVAILABLE

BUNDLE 02

Code: RGB02

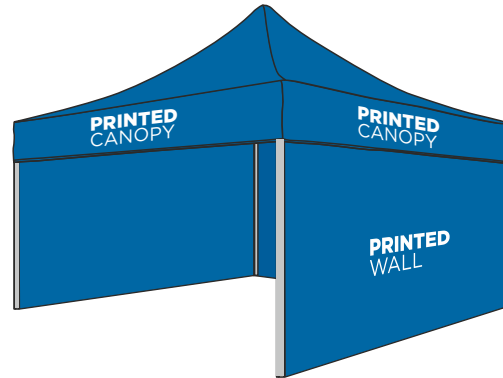

03 GAZEBO KIT 03

- 3x3m Rhino aluminum frame
- 1x Full colour canopy roof
- 3x Full single sided printed walls
- 1x Heavy duty wheeled case (gazebo)
- 2 x 3.2m feather flags printed single sided with ground spike

OTHER
FRAME
SIZES
AVAILABLE

BUNDLE 03

Code: RGB03

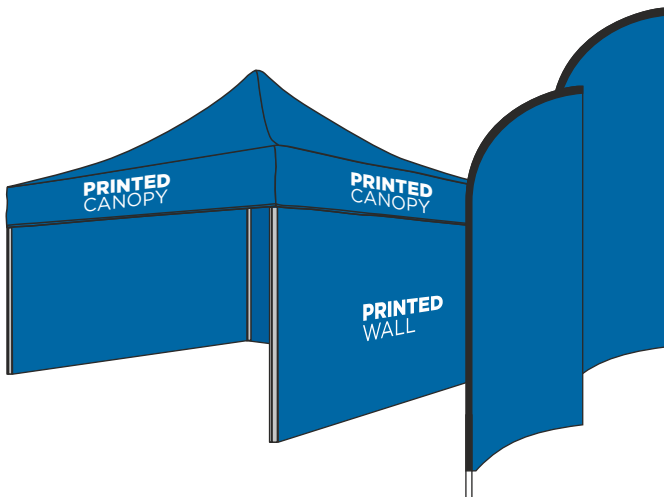

04 GAZEBO KIT 04

- 3x3m Rhino aluminum frame
- 1x Full colour canopy roof
- 2x Single sided half height walls
- 1x Full colour rear wall
- 1x Heavy duty wheeled case (gazebo)
- 1x Set of pegs
- 1x 3.2m Rhino feather flag printed single sided with ground spike
- 1x 6ft x 2ft table with table cloth

OTHER
FRAME
SIZES
AVAILABLE

BUNDLE 04

Code: RGB04

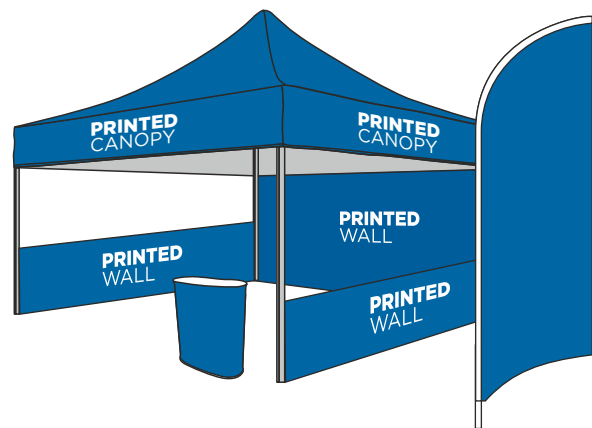

ST STAR TENTS

The Rhino Star tent is a promotional tent like no other. If you want to stand out from the crowd at your next exhibition, marketing or sports event then this is the tent for you.

The Rhino Star promotional tent comes in 4 different sizes, printed full colour with your brand – making it a truly unique marketing tool for your company. It's ideal for outdoor events and takes up an impressive surface area for such a portable and easy-to-assemble product.

Includes:

- Printed canopy
- Pole kit
- Wheeled canvas bag
- Galvanised steel pegs
- Rubber mallet

6M (w) x 5M (h)

Code: DZ-02

8M (w) x 5M (h)

Code: DZ-02

10M (w) x 5M (h)

Code: DZ-02

12M (w) x 6M (h)

Code: DZ-02

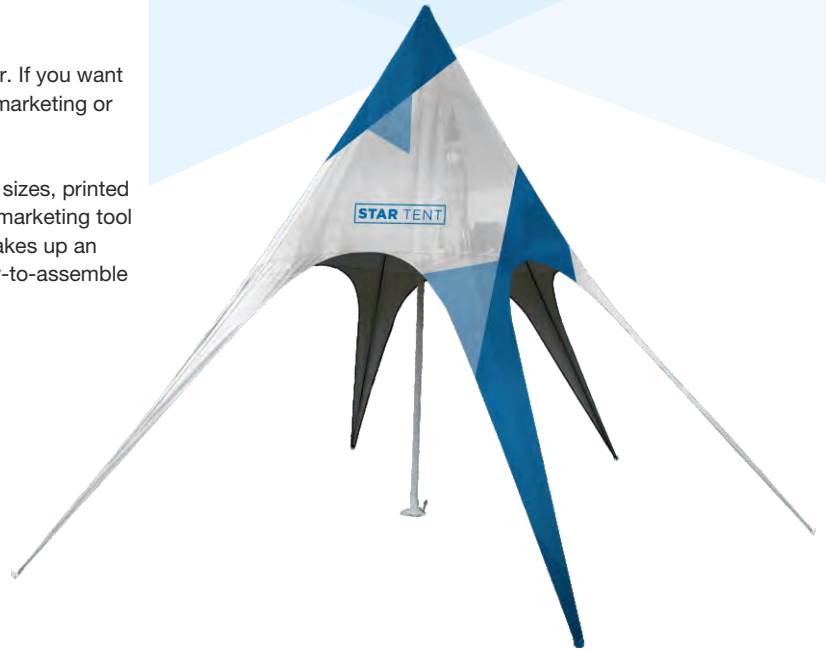

IT INFLATABLE TENT

Inflatable branded tent to create the ultimate inflatable display, which makes it extremely easy to setup using trapped air technology the tent, graphics printed directly onto the 220g polyester via dye sublimation for optimum results.

- Inflatable frame available in Grey and Black
- Supplied with a carry bag, 400w High pressure electric pump, PVC Spikes and Securing Straps included
- Supplied with Inner water pockets for the base of the legs
- Full colour single sided print to canopy and walls only
- Portable unit, simple to erect
- Wind speeds of up to 15mph/24kmh when pegged into soft ground
- Made from a strong polyester with double layer PE fabric outer shell

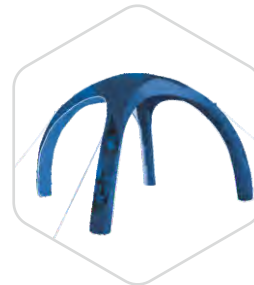

Inflatable tent with canopy*



Removable side wall*

INFLATABLE TENT FRAME SIZE

3M x 3M

Code: ITF33FS

4M x 4M

Code: ITF44FS

5M x 5M

Code: ITF55FS

PRINTED CANOPY ONLY

3M x 3M

Code: ITF33CP

4M x 4M

Code: ITF44CP

5M x 5M

Code: ITF55CP

PRINTED WALLS ONLY

3M x 3M

Code: ITF33WP

4M x 4M

Code: ITF44WP

5M x 5M

Code: ITF55WP





PROMOTIONAL CIRCULAR AND SQUARE PARASOLS

Ideal for outdoor events. Circular Parasol comes with winding handle for easy opening and closing as well as a safety chain and pin to prevent closing. Square Parasol clicks into place when fully opened. Carry bag included. Optional extra base and printed canopies available.

- Height: 2.13m
- Diameter (open): 1.8m
- MOQ: 1
- Panels: 8
- Panel Width (base): 62cm
- Panel Material: 150gsm Cotton
- Rib Length: 92cm
- Rib Material: Steel
- Stem Diameter: 22 & 26mm
- Stem Material: Steel
- Unit Weight: 2.1kg

CIRCULAR
Code: DZ-02

SQUARE
Code: DZ-02

BASE
Code: DZ-02



BASE SOLD SEPARATELY

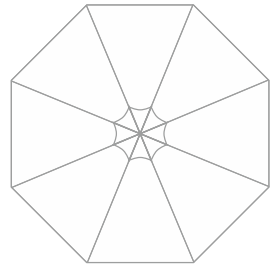

BASE SOLD SEPARATELY

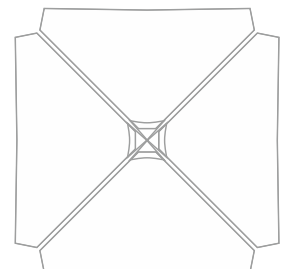

CARRY BAG INCLUDED





MONSOON BANNER FRAME

- Graphics included
- Indoor or outdoor banner system
- Suitable for single or double sided display
- 2 frame sizes 1000mm x 2500mm or 1250mm x 3000mm
- Wall Mounted version available
- Extension kits available
- Natural finish 25mm (1") square aluminium tubes with reinforced plastic mouldings
- Easy push-fit assembly, no tools necessary
- Graphics are secured to the frame with elastic bungee cords
- Supplied complete with carry bag, flat packs for easy transportation



SINGLE SIDED

1000MM X 2500MM	1250MM X 3000MM
Code: MBF1000-01	Code: MBF3000-01

DOUBLE SIDED

1000MM X 2500MM	1250MM X 3000MM
Code: MBF1000-02	Code: MBF3000-02



POP OUT BANNERS

Our pop up/spring up A frame banners will ensure maximum exposure of your brand, logo or message with minimum fuss. Printed double sided, and supplied with a carry bag and pegs.

HORIZONTAL A FRAME BANNER POLE SIZE

1200MM X 700MM	2000MM X 1000MM
Code: POB1200-01	Code: POB2000-01

2500MM X 1000MM	2730MM X 1360MM
Code: POB2500-01	Code: POB2730-01

VERTICAL A FRAME BANNER POLE SIZE

1000MM X 1500MM	1000MM X 2000MM
Code: POB1500-02	Code: POB2000-02

Also available in a Variety of other shapes and sizes, please ask for more details.



Horizontal pop out A Frame banner



Rectangular High Screen



Rectangular



Square



Triangular



3 Sided Tower



CB DELUXE CAFÉ BARRIER



- Make your own configuration
- Single or double sided graphics
- Suitable for indoor and outdoor use
- Heavyweight stainless steel post and concrete base
- Create various angles
- Quick and easy to assemble
- Heavy weight 14kg bases
- An alternative rope option is also available instead of a graphic banner
- Cross bars available in 1000mm/1500mm/2000mm lengths

Visual graphic area (approx.)

- 1000mm - 775 (h) x 850 (w) mm
- 1500mm - 775 (h) x 1350 (w) mm
- 2000mm - 775 (h) x 1850 (w) mm

Total hardware dimensions (approx.)

- Rail - 1440/1940/2440mm
- Post - 960mm (h)
- Base - 360mm (diam.)



Rail



Post



Base

1000MM	1500MM	2000MM
Code: BBS-02	Code: BBS-02	Code: BBS-02



(Cannot be left outside in all weathers)

FB FENCE AND EVENT BRANDING

Whatever kind of event or campaign you are running, our expertise in pitch banners, stadium banners, sponsorship banners and general event branding can help. Corporate function, large sporting event, festival, rock concert, charity event, party, conference, exhibition, advertising or experiential marketing campaign - we have a solution for you.

We can assist you to create the most captivating display using FABRIC to achieve the IMPACT that YOU or your sponsors demand. We are specialist in the design, production, logistics and installation of large FABRIC media - think big, very BIG!

Our event products include: Heras fencing scrim, Police/Crowd Barrier Covers, Flags & Flag Poles Stage Backdrops and Speaker Scrims, Podium / Press Backdrop Units, Wayfinding Signage, Banners, Window Graphics, Event Signage.

HF HERAS FENCING SCRIM

Ideal for large runs of branding and screening, turn an unsightly fence into a promotional opportunity. Perfect for mass participation events, temporary venues, on-street venues.

- Printed to Airflow perforated polyester
- Single panels or continuous runs
- Use for privacy screening and branding
- Supplied in roll form
- Very easy to install and remove
- Easy to recycle



CB CROWD AND BARRIER JACKETS

Used to provide branding and signage these jackets are idea for areas such as race start/finish areas.

- Printed to our Visionflag or Airflow polyester fabric
- Single or double sided
- Available to suit all barrier types and sizes



SP STADIUM PITCH GRAPHICS

Our Pitch Banners can be produced in any shape required to suit your design and pitch. Large banners add credibility to any brand sponsor allowing their logo or message to be seen with clarity by a large audience.

- Do not damage the pitch in any way
- Are light enough to easily deploy and remove rapidly
- Allow maximum visual impact for any advertisers benefit





EXPOVISION ROLLER BANNER

When cost and acceptable quality are important factors our Expovision stand is an attractive option. Designed with budget in mind offering a slightly more basic feel using the 'twist out feet' for stability.

- Padded carry bag
- 2 twist out feet add stability
- Compact lightweight base
- Still includes and hardware guarantee!
- Graphic Width: 800mm
- Visible Graphic Height: 2000mm
- Install Time in 25 seconds
- 3.1kg
- Single sided banner
- Includes a Carry Case (Foam Padded carry case with Shoulder Strap)



GRAPHIC OPTIONS

- A 500gsm Light block PVC So Flat.
- B 240mic Stop Light Polyester Film. Finished with protective scratch resistant over laminate finish

Replacement Graphic Service not recommended for the Expovision roller banner.

SIZE	CODE	GRAPHIC OPTION
850mm wide	EV850	A/B
1000mm wide	EV1000	A/B
1200mm wide	EV1200	A
1500mm wide	EV1500	A
2000mm wide	EV2000	A



Padded carry case included



Base with twist out feet





RHINO ROLLER BANNER

This roller banner is styled on a high popular base profile with silver casing it provides the perfect combinations for design with stability.

- 800mm x 2110mm width
- Choice of 800mm or 1000mm width
- Available in silver anodised finish with black end caps
- Includes quality padded carry bag



GRAPHIC OPTIONS

- A 500gsm Light block PVC So Flat.
- B 240mic Stop Light Polyester Film. Finished with protective scratch resistant over laminate finish

SIZE	CODE	GRAPHIC OPTION
800mm wide	RR800	A/B
1000mm wide	RR1000	A/B

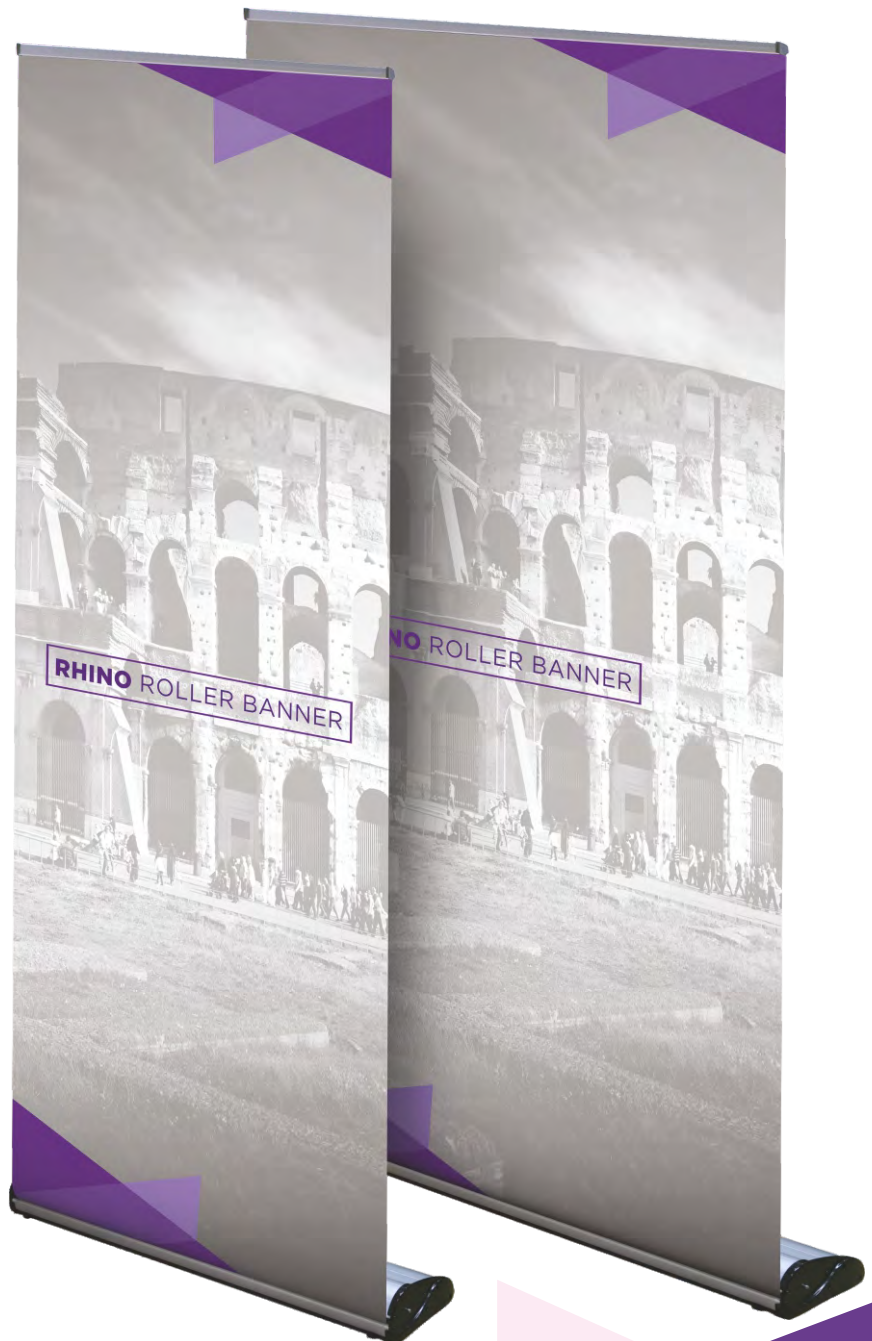

M2

MIRAGE 2 ROLLER BANNER

- Single or double sided
- Wide footprint for extra Stability
- Available in 800mm and 1000mm widths
- Available in anodised silver
- Fast graphic change
- Height 2130mm
- Finished with protective scratch resistant over laminate finish

GRAPHIC OPTIONS

- A** 500gsm Light block PVC So Flat.
- B** 240mic Stop Light Polyester Film. Finished with protective scratch resistant over laminate finish

SIZE	CODE	GRAPHIC OPTION
800mm wide	M2-800	A/B
1000mm wide	M2-1000	A/B
1200mm wide	M2-1200	A
1500mm wide	M2-1500	A
2000mm wide	M2-2000	A
2400mm wide	M2-2400	A



Double banner



NV

VOGUE ROLLER BANNER

- Standard graphic height (approx.) 2145mm
- Grand format and custom sizes available
- Adjustable height telescopic pole
- Rail with secure black end caps
- Linear accessories channel



GRAPHIC OPTIONS

- A** 500gsm Light block PVC So Flat.
- B** 240mic Stop Light Polyester Film. Finished with protective scratch resistant over laminate finish

SIZE	CODE	GRAPHIC OPTION
600mm wide	NV600	A/B
800mm wide	NV800	A/B
1000mm wide	NV1000	A/B
1200mm wide	NV1200	A
1500mm wide	NV1500	A
2000mm wide	NV2000	A
2400mm wide	NV2400	A
3000mm wide	NV3000	A



SN SPECTRE + CASSETTE ROLLER BANNER

- Exclusive design
- Standard graphic height (approx.) 2130mm
- Cassette banner
- Quick change graphics
- Adjustable feet and adjustable height telescopic pole
- Stylish black end covers
- Supports Linear accessories

GRAPHIC OPTIONS:

- A 500gsm Light block PVC So Flat.
- B 240mic Stop Light Polyester Film. Finished with protective scratch resistant over laminate finish

SIZE	CODE	GRAPHIC OPTION
850mm wide	SC850	A/B
1000mm wide	SC1000	A/B



Stylish and easy to use cassette banner



Hybrid adjustable height pole



Cassette lock

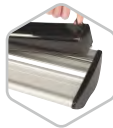

Quick change graphics cassette



Premium padded bag



NV ILLUSION CASSETTE ROLLER BANNER

- Standard graphic height (approx.) 2000mm
- Cassette banner
- Quick change graphics
- Adjustable height telescopic pole and snap rail
- Adjustable feet
- Stylish black end covers
- Padded bag
- Exclusive design

GRAPHIC OPTIONS:

- A 500gsm Light block PVC So Flat.
- B 240mic Stop Light Polyester Film. Finished with protective scratch resistant over laminate finish

SIZE	CODE	GRAPHIC OPTION
600mm wide	IC600	A/B
800mm wide	IC800	A/B
1000mm wide	IC1000	A/B
1200mm wide	IC1200	A



Hybrid adjustable height pole





ORIENT ROLLER BANNER

This smart roller banner is styled on a highly popular base profile, with a substantial anodised silver casing it provides the perfect combination of design with stability.

- 800mm (w) x 2110mm (h) standard visible graphic area
- Stylish lightweight components
- Quick to assemble and easy to use
- Ideal for point of sale, retail or exhibitions
- Available in a choice of 800mm up to 2000mm width
- Available in Silver anodised finish
- Includes quality foam padded carry bag

GRAPHIC OPTIONS

- A** 500gsm Light block PVC So Flat.
- B** 240mic Stop Light Polyester Film. Finished with protective scratch resistant over laminate finish

SIZE	CODE	GRAPHIC OPTION
800mm wide	OR800	A/B
1000mm wide	OR1000	A/B
1200mm wide	OR1200	A
1500mm wide	OR1500	A
2000mm wide	OR2000	A



Front entry graphic

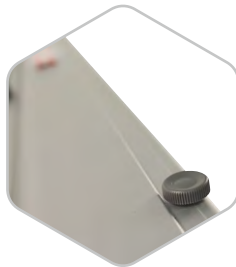

Adjustable feet for levelling

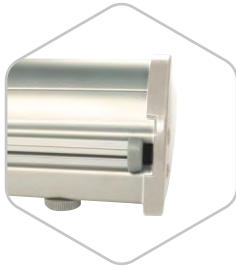

Patent pending Universal Rail with secure end caps





BARRACUDA ROLLER BANNER

A very popular, strong and stylish design, proven as a reliable banner for regular use. Ideal for simple displays or exhibitions. Position your graphic to the height required with the hybrid adjustable height telescopic pole.

- Standard graphic height (approx.) 2130mm
- Strong and durable design
- Large internal graphic housing with tensioner
- Rail with secure end caps
- Adjustable height telescopic pole
- Stylish end covers
- Exclusive design

GRAPHIC OPTIONS

- A** 500gsm Light block PVC So Flat.
- B** 240mic Stop Light Polyester Film. Finished with protective scratch resistant over laminate finish

SIZE	CODE	GRAPHIC OPTION
800mm wide	BR800	A/B
1000mm wide	BR1000	A/B
1200mm wide	BR1200	A
1500mm wide	BR1500	A
2000mm wide	BR2000	A
2400mm wide	BR2400	A



Image description



Adjustable height pole



Rail with secure end caps



End profile



Adjustable feet



Tensioner



Adjust the banner height with adjustable height telescopic pole

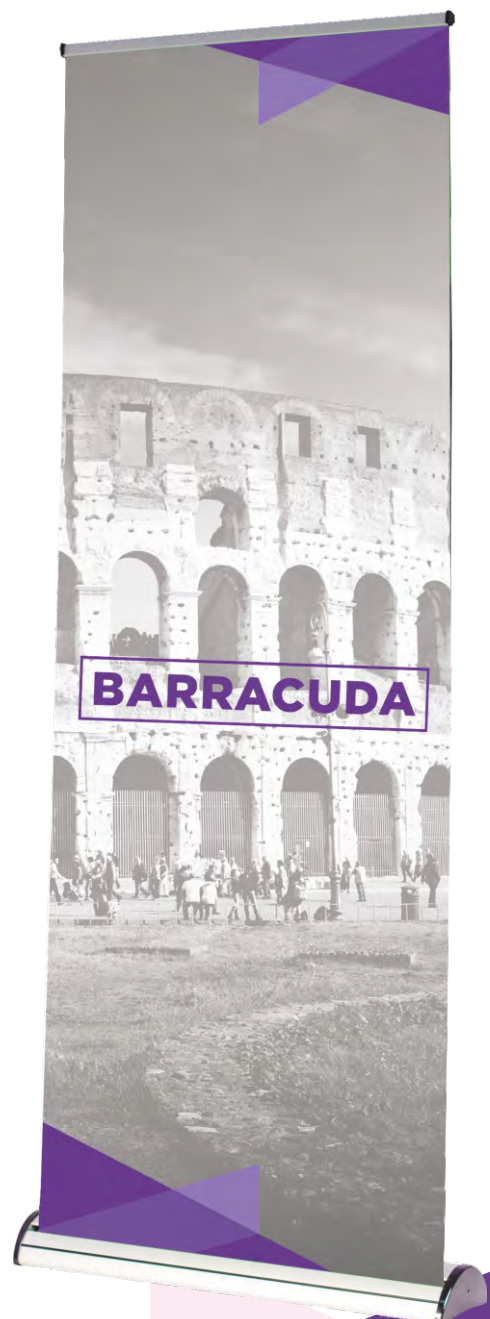

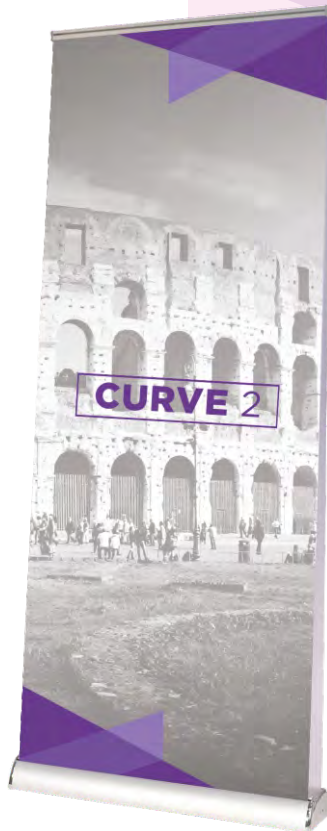
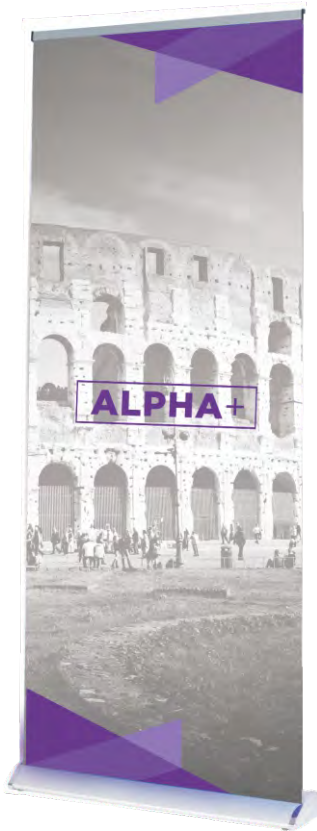

A+ **ALPHA+**
ROLLER
BANNER

- Low profile design
- Standard graphic height (approx.) 2110mm
- Stylish end covers in chrome finish
- Adjustable feet
- Adjustable height telescopic pole
- Quality snap rail
- Premium padded bag
- 500gsm Light block PVC So Flat

850MM
Code: ARB850

1000MM
Code: ARB1000



C2 **CURVE 2**
ROLLER
BANNER

- Double-sided banner
- Standard graphic height (approx.) 2000mm
- Snap rails with end caps
- Three part bungee pole
- Chrome finished end covers
- Exclusive design
- Premium padded bag
- 500gsm Light block PVC So Flat

850MM
Code: CR850

1000MM
Code: CR1000



RR **RAYO**
ROLLER
BANNER

- Standard graphic height (approx.) 2000mm
- Adjustable height telescopic pole
- Snap rail
- Snap roller instead of self-adhesive leader
- Top opening to gain access to the snap roller
- Single, rear twist-out foot
- 500gsm Light block PVC So Flat

850MM
Code: RR850

1000MM
Code: RR1000





VD VISION DESK A4/A3 ROLLER BANNER

- Standard graphic height (approx.) A4 297/ A3 420mm
- Self-adhesive top rail
- Ideal budget banner
- Aluminium with anodised silver finish

A4

Code: VDRA4

A3

Code: VDRA3



VM VISION EXTEND MINI ROLLER BANNER

- Standard graphic height (approx.) 400/800/1200/1600mm
- Four part pole*
- Snap rail
- Stable footprint: 430 (w) x 125 (d) mm
- Grey end covers
- Ultra compact

400MM

Code: VEM400

800MM

Code: VEM800

1200MM

Code: VEM1200

1600MM

Code: VEM1600



BB BLIZZARD BANNER

Blizzard is ideal for all kinds of corporate and sporting and outdoor events and promotions and point of sale. Its simple design makes it very easy to assemble on-site, and because it's adjustable, it can accommodate different graphic sizes to suit your application.

- Stylish design hollow plastic base for water or sand weighting agent
- Base holds 15 litres water approx
- Telescopic pole for adjustable height
- Weather resistant
- Optional carry bag
- Withstands winds up to 13-18mph approx
- Size: 800mm (w) x 2000mm (h)
- Choose from display fabric polyester material or PVC banner material* (*PVC banner material at additional cost)

800MM (W)

Code: BBS-02

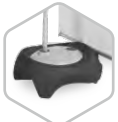

Base



Reverse



SH STORM HYDRO

Built for durability and strength, the Storm Hydro 2 is ideal for indoor or outdoor promotion, and as it can be used to present a double-sided graphic, is ideal for areas where there is 2-way traffic. Graphics are held with a simple eyelet system that allows for quick and easy assembly.

- Can be used as a single or double-sided unit
- Moulded plastic base for water or sand weighting
- Supported by simple eyelet system
- Weather resistant
- Supplied with carry bag
- Withstands winds 10-12mph approx (Beaufort scale 3)
- Size: 800mm (w) x 1800mm (h)
- Choose from display fabric polyester material or PVC banner material* (*PVC banner material at additional cost)

800MM (W)

Code: SHS-02

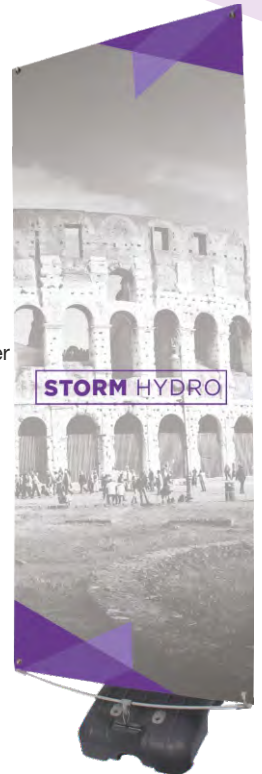

TB THUNDER BANNER

The only double-sided retractable outdoor banner. Thunder is the ideal roller banner for outdoor use being strong and durable yet very easy to assemble and transport. At 2m high Thunder will display your message on both sides for maximum viewing impact.

- Double sided outdoor banner
- Large Twin feet
- Three part bungee pole
- 2m high
- Beaufort scale 5 if pegged (18-24mph)
- Beaufort scale 2 if unpegged (4-7mph)
- PVC Banner Graphic
- Padded bag included
- Size: 850mm (w) x 2025mm (h)

850MM (W)

Code: TBS-02



Base



HB HURRICANE BANNER

The hurricane banner outdoor double sided roll-up banner offers great versatility for campaigns all year round.

- Double sided outdoor banner
- Moulded plastic base can be filled with sand/water for additional stability
- Twist-out foot for extra support
- Wheeled base for ease of transportation
- PVC Banner Graphic
- Includes carry-bag
- Size: 800mm (w) x 2000mm (h)

800MM (W)

Code: HBS-02



PB PEGASUS FABRIC TENSION BANNER

The Pegasus is a giant single sided tension banner stand is ideal for creating large graphic backdrops for exhibition stands, retail displays, and Media boards and branding environments.

- Adjustable telescopic pole
- Lightweight frames & fixings
- Dismantles easily for transportation
- Cost effective
- Finished with a silver/black powder coat
- Printed on display fabric polyester material

1500MM x 2410MM

Code: PTB15-01

2000MM x 2410MM

Code: PTB20-01

2400MM x 2410MM

Code: PTB24-01



PS PRO SCREEN BANNER

A clever way for an alternative use of a roller banner. Turn your banner into a projector screen with smart printing technology.

- 1500mm wide portable, free-standing, retractable projection screen
- 2 x bungee pole and snap rail
- Padded bag
- Screen size (approx) 1070 (h) x 1430 (w) mm
- 70" diagonal
- Aspect ratio 4:3

1500MM

Code: PSB1500

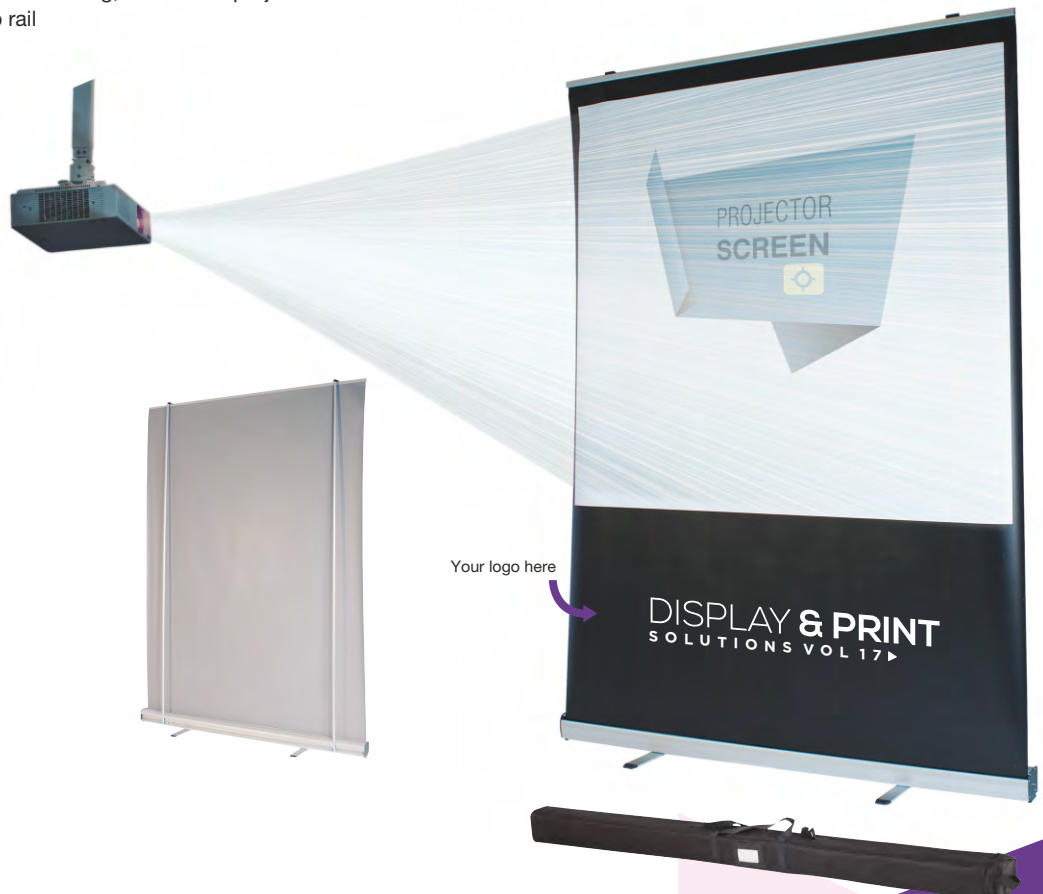



SOFT TOUCH WHERE FORM MEETS FUNCTION

Soft Touch is a range of standard structures that are manufactured from strong, yet lightweight, tubular aluminium which is then dressed with a tensioned fabric graphic.

Stretching a tough fabric graphic over the structure changes it from a simple frame to an elegant, engaging form, suitable for various situations and applications.

The Soft Touch range consists of fabric displays, available in various widths and configurations; shaped counters, impressive retail and exhibition structures, hanging structures and a multitude of accessories.

LIGHTWEIGHT, IMPRESSIVE DISPLAY IN TWO EASY STEPS

Soft Touch fabric displays are aluminium structures with textile fabric graphic socks that wrap snugly around each frame.



Push tubes together following the numbers (start at number 1).

Depress the button making sure tubes click together to build the frame



Completed structure



Slide fabric graphic over frame, secure with heavy duty zip, and add feet for stability.

HERE'S WHY SOFT TOUCH IS PROVING SO POPULAR

- Each structure is manufactured from lightweight but strong 32mm diameter aluminium framework making the kit easily portable.
- Each of the connecting frame sections are labelled with matching numbers and have a bungee cord inside, meaning that it is much easier to assemble and saves time compared with other types of display equipment.
- The elasticity within the fabric makes the graphics extremely durable and long lasting giving a great return on investment.
- Attaching the graphics is simple! Each graphic slides effortlessly over the framework and zips closed.
- Kits pack away into a small carry bag making them convenient to transport and store.
- Graphics are easy to care for. After use, zip closed, fold up and place into the bag. If the graphics get dirty during use they can be washed.



Numbered tubes and bungee cord make for easy assembly

SC SOFT TOUCH CURVED FABRIC DISPLAY



Total hardware dimensions (approx.):

- 2.4m (8ft) 2438 (w) x 2280 (h)
- 3m (10ft) 3000 (w) x 2280 (h)
- 6m (20ft) 5960 (w) x 2280 (h)

2.4M	3M
Code: STC24	Code: STC3
6M	
Code: STC6	



SS SOFT TOUCH STRAIGHT FABRIC DISPLAY



Total hardware dimensions (approx.):

- 2.4m (8ft) 2438 (w) x 2280 (h)
- 3m (10ft) 2922 (w) x 2280 (h)
- 6m (20ft) 5960 (w) x 2280 (h)

2.4M	3M
Code: STS24	Code: STS3
6M	
Code: STS6	



SS SOFT TOUCH FABRIC BANNER STANDS



These displays are guaranteed to grab attention. Available in several widths and seated on a heavy metal base. Soft Touch fabric banner stand promote a strong brand image.

- Includes vibrant fabric print
- Fully washable graphic
- Tubular frame
- Heavy base
- Single or double sided

917MM x 2300MM	1222MM x 2300MM
Code: EZ915ST	Code: EZ1220ST
1526MM x 2300MM	
Code: EZ1524ST	



SS SOFT TOUCH FABRIC IPAD STAND



Lightweight and strong, our stretch fabric iPad stand comes in a unique shape and can be fully branded with your own logos and graphics.

- Size approx 410mm (w) x 1880mm (h)
- Fully washable dye-sublimation fabric
- Easy to assemble push-fit tubular framework
- One piece zip-on fabric graphic – double sided print
- Packs into supplied bag for transport

IPAD STAND
Code: IPAD01



ST SOFT TOUCH FABRIC COUNTER



The Soft Touch fabric counters is striking and unique. Part of the Soft Touch range, the Promo Oval Counter, Long Oval Counter and Square Counter has a base and top supported by three poles. A tensioned fabric sock is attached using silicone edged material. The counters are quick and simple to assemble.

- Quick and Simple to assemble
- Available in 3 shapes
- Stylish statement and useful counter
- Vibrant, washable dye sublimation printed included
- Packs into supplied bag for transport
- Additional prints can be purchased separately

A. PROMO OVAL COUNTER
Assembled Size: 595mm (w) x 395mm (d) x 1000mm (h) Code: STFCA
B. LONG OVAL COUNTER
Assembled Size: 720mm (w) x 395mm (d) x 1000mm (h) Code: STFCE
C. SQUARE COUNTER
Assembled Size: 800mm (w) x 530mm (d) x 1000mm (h) Code: STFCC

A



B



C



TS TEXSTYLE CONCERTINA POP UP COUNTER RECTANGLE

- Ideal for trade shows and events
- Assembled size: 1000mm tall x 800mm wide x 530mm deep
- Contemporary appearance
- Simple assembly, counter ready to go in seconds
- No tools required
- The fabric graphic doesn't have to be removed to transport
- Supplied in a smart semi-rigid case

TEXSTYLE
Code: TX01



SP SEG POP UP FABRIC COUNTER

The SEG Pop-up counter is a quick and easy counter to assemble using the pop-up frame mechanism and comes complete with base, frame, two shelves, table top, bag and box.

- Display counter with thermoformed top
- Top available in 4 different colour options
- Pop-Up frame mechanism for easy transportation and set up
- Comes complete with bag and box
- Lightweight for ease of moving around
- Two shelves for storage
- Size 840mm (w) x 990mm (h) x 365mm (d)

SEG POP UP
Code: SPU1



ST

SOFT TOUCH SNAKE FABRIC DISPLAY



Soft Touch Snake fabric display is a visually arresting large banner stand. Stretch the fabric sock over the tubular frame. With vibrant fabric print Snake is bound to draw attention.

Ideal for retail or for exhibitions. Snake is beautifully curvy. It is a seductive alternative to a straight up and down banner stand. Lightweight and portable, the Snake is easy to assemble and disassemble. It comes complete with its own fabric carry bag. The Soft Touch range of displays share a common construction. 32mm aluminium tubing push-fits to form a light but strong frame. Each piece of the tube frame is labelled at both ends. Just match the labels and connect the tubes. The joins click into place. When finished 16mm bungee poles are added as you can see in the video below. These act as spacers. Soft Touch frames weigh only a few kilograms when assembled They are however strong and rigid.

- Quick and Simple to assemble
- Choose from 3 different shapes:
- Snake Curved/Snake Straight/Snake Slant
- Size: 915mm width x 2280mm height
- Fully washable dye-sublimation fabric
- Easy to assemble push-fit tubular framework
- One piece zip-on fabric graphic – double sided print
- Packs into supplied bag for transport
- Large powerful display

SP

SOFT TOUCH SNAKE CURVED

Total hardware dimensions (approx.):
• 915mm (w) x 2280 (h)

SNAKE CURVED

Code: STC915

SS

SOFT TOUCH SNAKE STRAIGHT

Total hardware dimensions (approx.):
• 915mm (w) x 2280 (h)

SNAKE STRAIGHT

Code: STS915

SC

SOFT TOUCH SNAKE SLANT

Total hardware dimensions (approx.):
• 915mm (w) x 2280 (h)

SNAKE SLANT

Code: STSS915





SOFT TOUCH FABRIC HANGING BANNERS

The Soft Touch Fabric Hanging Banner is a must have if you want to get noticed. These extra large hanging banners are produced from high quality fabric and enables your booth to be seen from practically anywhere at your trade show. Available in round, square, and triangle configurations as well as numerous sizes, there is a Hanging Banner that would suit almost any situation. Sizes available from 5ft, 8ft, 10ft, 14ft, 16ft, and 20ft, Please ask our sales team for more information.



TRIANGLE HANGING BANNER
Code: THB01



CIRCLE HANGING BANNER
Code: CHB02



PINWHEEL HANGING BANNER
Code: PHB03



CURVED TRIANGLE HANGING BANNER
Code: CTHB04



FOOTBALL HANGING BANNER
Code: FHB05



TAPERED CIRCLE HANGING BANNER
Code: TCHB06

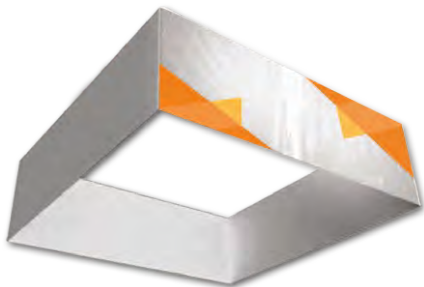

SQUARE HANGING BANNER
Code: SHB07



RECTANGLE HANGING BANNER
Code: RHB08



SOFT TOUCH FABRIC NON-LIT WALL

Linear Vector wall mounted frames are the easy way to create the perfect environment, whether it's a corporate or commercial interior or a retail display where you need to change your message frequently. 19mm - 120mm frame depth available.

- Aluminium wall mounted graphic frames, available portrait or landscape
- For use with lightweight dye-sublimated fabric graphics for easy assembly with silicone and beaded edges*
- Large displays can be created using multiple frames, custom made to order sizes available

POSTER SIZE - (W) X (H) MM	CODE
A0 - 841mm x 1189mm	LVA0
A1 - 594mm x 841mm	LVA1
A2 - 420mm x 594mm	LVA2
B0 - 1000mm x 1414mm	LVB0
B1 - 707mm x 1000mm	LVB1



BESPOKE SIZES AVAILABLE



ST NEW SOFT TOUCH FABRIC EXHIBITION STANDS

Soft Touch booth solutions It is a versatile, reconfigurable exhibit system. booth solutions kits are comprised of various aluminum tube frame banners with unique curves, shapes and corners. Booth solution series, including the standard combination, concave series, multi-storey ceiling hanging banner series, arch series and customized series, we provide a range of 10ft, 20ft, 30ft booth solution, which will be a suitable for you needs.

Frames feature printed pillowcase fabric graphics that slip over easily and zip at the bottom. Linking clips connect the frames together at a 180-degree angle and universal feet connect the tube frames at the bottom. Displays come in durable, portable carry bags and optional expandable cases are available as an upgrade.



13



14



15



16



17



18



19



20



21



22



23



24



25



26



27



28



29



30



31



32



33





VISION POP UP DISPLAY STAND

Includes:

- Pop-Up Stand Frame 3x2/3x3/3x4, Curved or Straight
- Printed on 320 micron stoplight polyester film, Finished with protective scratch resistant over laminate finish
- Integrated Trolley Case with wooden table top
- 2x halogen lights with all sizes

SIZE	CODE
3x2 Curved	POP32C
3x3 Curved	POP33C
3x4 Curved	POP34C
3x2 Straight	POP32S
3x3 Straight	POP33S
3x4 Straight	POP34S



CURVED POP UP

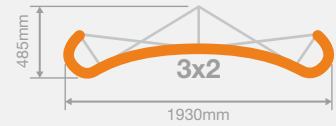
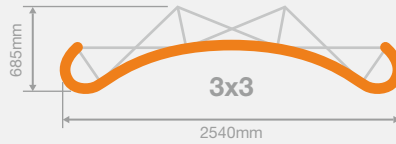
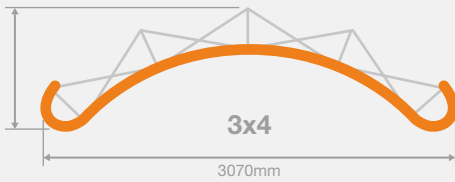

STRAIGHT POP UP

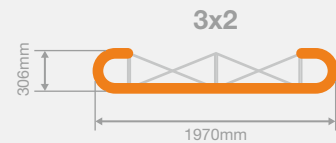
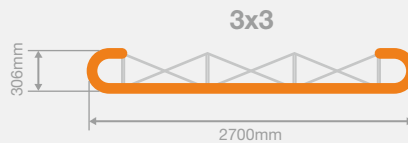
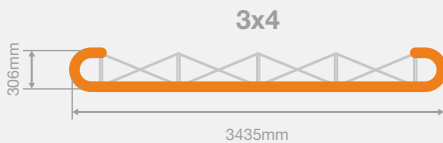

OPTIONAL EXTRAS

- A** Graphic wrap for wheeled case
Code: **GWWC**
- B** Flush mounted tabletop iPad holder
Code: **FMTI**
- C** Pop-up monitor/TV bracket
Code: **PMTV**



P1 POP UP DISPLAY PRO KIT 1

Includes:

- 1x Pop-Up Stand Frame 3x3
- 1x High Quality Printed Graphics
- 1x Integrated Trolley Case
- 1x 2X Lights for popup
- 1x Case to Counter Conversion
- 1 x Printed Wrap for Case



STRAIGHT

Code: PROS3X3-1

CURVED

Code: PRO3X3-1

P2 POP UP DISPLAY PRO KIT 2

Includes:

- Pop-Up Stand Frame 3x3
- High Quality Printed Graphics
- Integrated Trolley Case
- 2x Lights for popup
- Case to Counter Conversion
- Printed Wrap for Case
- 1x Banner Stands
- Zed Up Literature Rack



3x3 Pop-Up Stand printed on 320mic Stop Light Polyester Film. Finished with protective scratch resistant over laminate finish

Roller Banners Printed on 180mic Polyprop

STRAIGHT

Code: PROS3X3-2

CURVED

Code: PRO3X3-2

P3 POP UP DISPLAY PRO KIT 3

Includes:

- Pop-Up Stand Frame 3x3
- High Quality Printed Graphics
- Integrated Trolley Case
- 2x Lights for popup
- Case to Counter Conversion
- Printed Wrap for Case
- 1x Banner Stands
- Zed Up Literature Rack
- 1x TV mount up to 22"



STRAIGHT

Code: PROS3X3-3

CURVED

Code: PRO3X3-3

P4 POP UP DISPLAY PRO KIT 4

Includes:

- Pop-Up Stand Frame 3x3
- High Quality Printed Graphics
- Integrated Trolley Case
- 2x Lights for popup
- Case to Counter Conversion
- Printed Wrap for Case
- Zed Up Literature Rack
- 2.3m Feather flag with cross base



3x3 Pop-Up Stand printed on 320mic Stop Light Polyester Film. Finished with protective scratch resistant over laminate finish

Roller Banners Printed on 180mic Polyprop

STRAIGHT

Code: PROS3X3-4

CURVED

Code: PRO3X3-4



QUICK+ TOWER POP UP

- Round Pop-up tower
- Choice of heights up to four quads
- Lights optional extra
- Linking cables for internal lights available, which are recommended

Visible graphic area (approx.):

- 3 Quad: 2225 (h) x 2019 (w) mm
- 4 Quad: 2968 (h) x 2019 (w) mm

Total hardware dimensions (approx.):

- 2265 (h) x 640mm diameter
- Based on 3 quad

STRAIGHT

Code: QTPU



DESKTOP POP-UP 2x2

- Stylish tabletop graphic
- Very quick to set up
- Collapses to a fraction of its full size making it easy to store and transportation

Visible graphic area (approx.):

- Total: 1219 (h) x 1907.4 (w) mm
- D-ends: 1219 (h) x 426.4 (w) mm
- Curved front: 1219 (h) x 558.8 (w) mm

Total hardware dimensions (approx.):

- 1219 (h) x 1466 (w) x 298 (d) mm

STRAIGHT

Code: DPU22





CURVED BANNER STAND

Curve exhibition stand sold only as a 3 panel kit complete with hardware, graphics, packaging and graphics tube, it has been designed to fill the gap between the numerous budget exhibition stands and pop up display stands.

The Curve allows you to create and recreate virtually any shape you require without having to change hardware or graphics.

- Visible Size: 2025mm (w) x 2060mm (h)
- 2 x 850mm wide panels
- 1 x 425mm wide panel (flexi panel)
- 3 panel system
- Total Weight inc of hardware and graphic 15kg
- Turn a single side curve to a double sided by adding extra graphic panels
- Quick change graphic facility
- Weighted Anti-slip base
- Optional Lights Available
- Carry cartons & graphic tubes included

Graphics printed 320mic Polyester Film, Finished with protective scratch resistant over laminate finish



???
Code: CBS-01



VISION FABRIC WALL

Traditionally linking Uno banner stands are printed on fabric material, which allows them to be linked easily with the Vision fixing kit. However, for companies who are looking for a compact, lightweight option, we supply Vision with fabric graphic panel, making the Vision fabric wall extremely lightweight.

Developments to Vision now allow multiple frames to be linked together with one complete fabric graphic panel to cover the full width. This makes Vision a very cost effective linking banner that can switch between sizes and updated graphics, on different materials for years of versatile display use.

Vision fabric wall Kit comes with the correct number of Vision's depending on length required along with the magnetic connectors and printed fabric graphics

2M UNO FABRIC WALL KIT
Code: BLR850-1

3M UNO FABRIC WALL KIT
Code: BLR850-1

4M UNO FABRIC WALL KIT
Code: BLR850-2

5M UNO FABRIC WALL KIT
Code: BLR850-2



A+ AERO PLUS

- Adjustable graphic heights, maximum height 1890mm
- Linkable and reconfigurable roller banner system
- Multiple positions to suit area, add sections as required
- Slim profile
- Plastic linking hooks

Total hardware dimensions* (approx.)
based on a 1000mm cassette:

- 2120 (h) (max) x 1600 (w) x 500 (d) mm*

based on a 1500mm cassette:

- 2120 (h) (max) x 2100 (w) x 500 (d) mm*

based on a 2000mm cassette:

- 2120 (h) (max) x 2600 (w) x 500 (d) mm*

*Depends on configuration

2120MM x 1600MM

Code: AP1600

2120MM x 2100MM

Code: AP2100

2120MM x 2600MM

Code: AP2600



Banner can be raised from the base using the adjustable collars anywhere along the lower pole



LED Flood light, further LED lighting options on page 129

A modular solution

Optional extra Halogen or LED lighting can be placed over the banner - previously could only be sited on posts



Multiple positions



Folding feet



Adjustable collar on telescopic legs



Special cassette locking system



Tension graphic

TD TWIST DISPLAY SYSTEMS

Twist is one of the most portable, flexible and modular display systems available today. The Twist range of products has been designed to add flexibility, portability and value for money to any exhibition or display situation. Manufactured in the UK, Twist products can be used in any exhibiting situation from a single banner stand, shell scheme, or a bespoke stand.

OT ORIGINAL TWIST BANNER

- Available in 2000, 2250 and 2700 (mm) height
- Available in 700, 800, 900 and 1000 (mm) width
- Sides: single sided or double sided
- High quality photo realistic printed graphic
- Includes canvas carry case
- LED Lights included

ORIGINAL TWIST

Code: OTB



SM SINGLE MEDIA TWIST

- Available in 2000, 2250 and 2700 (mm) height
- Available in 700, 800, 900 and 1000 (mm) width
- Sides: Single Sided or Double Sided
- High quality photo realistic printed graphic
- Includes Canvas Carry Case
- LCD Screen not included
- LED Lights included

SINGLE MEDIA TWIST

Code: SMT

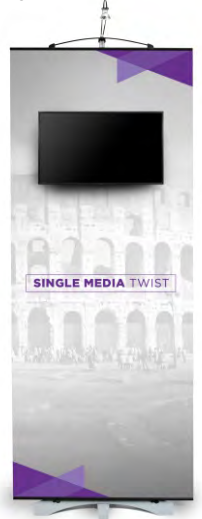

T2 TWIST 2 PANEL STRAIGHT

The Twist 2 panel straight kit offers two displays in one. You can choose to have one seamless straight display or split the banners into two individual displays.

Includes:

- 2x Twist banners with printed graphics
- 1x Rear easi-link joining kit
- 2x Carrying bag sets
- 2x LED spotlights or two individual displays.

TWIST 2 PANEL

Code: T2P

Available in three different heights and four widths
Height: 2000mm, 2250mm, 2700mm
Width: 1400mm, 1600mm, 1800mm, 2000mm



T3 TWIST 3 FLEXI LINK

The Twist Flexi Link 3 modular system is one of the most versatile banners on the market. The flexi-link aspect of this display is a 550mm wide graphic panel that sits in-between the main Twist banners and allows you to create controlled, seamless curves as well as straight back walls.

Includes:

- 2x Twist banners with printed graphics
- 1x Bridging panel
- 1x Wheeled Carrying Case
- 2x LED spotlights

TWIST 3 PANEL

Code: T3FL

Available in three different heights and four widths
Height: 2000mm, 2250mm, 2700mm
Width 1950mm, 2150mm, 2350mm, 2550mm



BB TWIST 5 PANEL FLEXI LINK

Flexi Link Twist banners are one of the most versatile exhibition systems on the market, incorporating bridging graphic panels. The panels sits in-between the main banners allowing you to create controlled, seamless curves as well as straight back walls.

Includes:

- 3x Twist banners with printed panels
- 2x - 550mm (w) flexi-link bridging panel
- 2x - Rear flexi-linking kits
- 3x - LED spotlights
- 1x - Wheeled transit cases
- 1x - Padded carrying bag set

TWIST 5 PANEL

Code: T5P

Available in three different heights and four widths
Height: 2000mm, 2250mm, 2700mm
Widths: 3200mm, 3500mm, 3800mm, 4100mm



HS TWIST 7 PANEL FLEXI LINK

The 7 Panel Flexi-Link Twist Display Stand is the most flexible banner system on the market. The flexi-link aspect of this display is a 550mm wide bridging panel that sits in-between the main Twist banners, thus allowing you to create controlled, seamless curves as well as straight back walls.

Includes:

- 4x Twist banners with printed panels
- 3x 550mm (w) flexi-link bridging panel
- 3x Rear flexi-linking kits
- 4x Spotlights
- 2x Wheeled transit cases

TWIST 7 PANEL

Code: SHS-02

Available in three different heights and four widths
Height: 2000mm, 2250mm, 2700mm
Widths: 4450mm, 4850mm, 5250mm, 5650mm



BB TWIST 3 PANEL STRAIGHT

The Twist visual presentation stand is a user friendly banner system that packs neatly away into three easy to transport carrying bag sets, and is a popular choice for those wanting a portable audio visual display stand.

Includes:

- 3x Twist banner stands with printed panels
- 2x Rear easi-linking kits
- 1x VESA TV Mount (Screen not included)
- 3x Padded carrying bag sets
- 3x Spotlights

TWIST 3 PANEL

Code: T3PS

Available in three different heights and four widths
Height: 2000mm, 2250mm, 2700mm
Widths: 2100mm, 2400mm, 2700mm, 3000mm

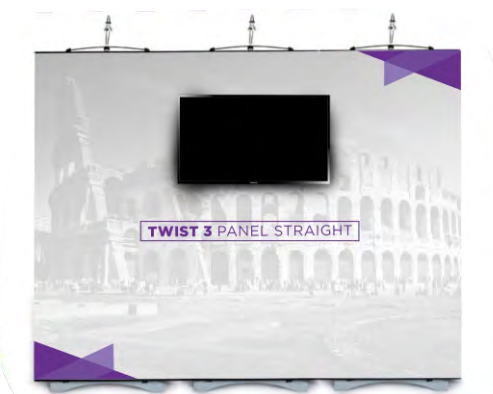

HS TWIST 6 PANEL WITH SHELFING

The 6 panel Twist linked banner display enables you to create controlled, seamless curves as well as straight back walls. The added bonus to this particular package is that it incorporates shelving so you can display related products and merchandise, without taking up any further floor space.

Includes:

- 4x Twist banners with printed panels
- 2x Twist flexi-link bridging panel
- 4x Shelves 800mm wide (2kg load bearing)
- 4x LED spotlights
- 2x Wheeled transit cases

TWIST 6 PANEL

Code: T6PS

Available in three different heights and four widths
Height: 2000mm, 2250mm, 2700mm
Widths: 3900mm, 4300mm, 4700mm, 5100mm

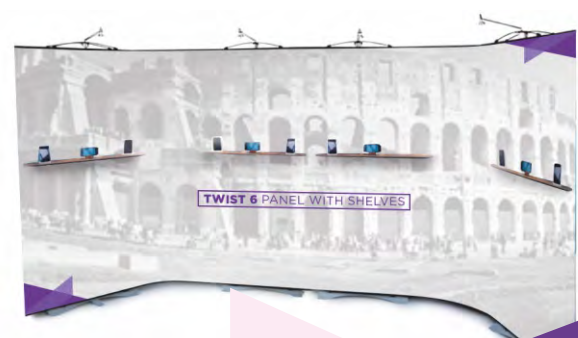

SB STEALTH BANNER

Modular, linkable banner system. Create seamless graphic back walls, link single or double-sided units and position at different angles for extra impact*

* Minimum panel width of 600mm. Double-sided graphics on straight configurations only

STEALTH
Code: SB600

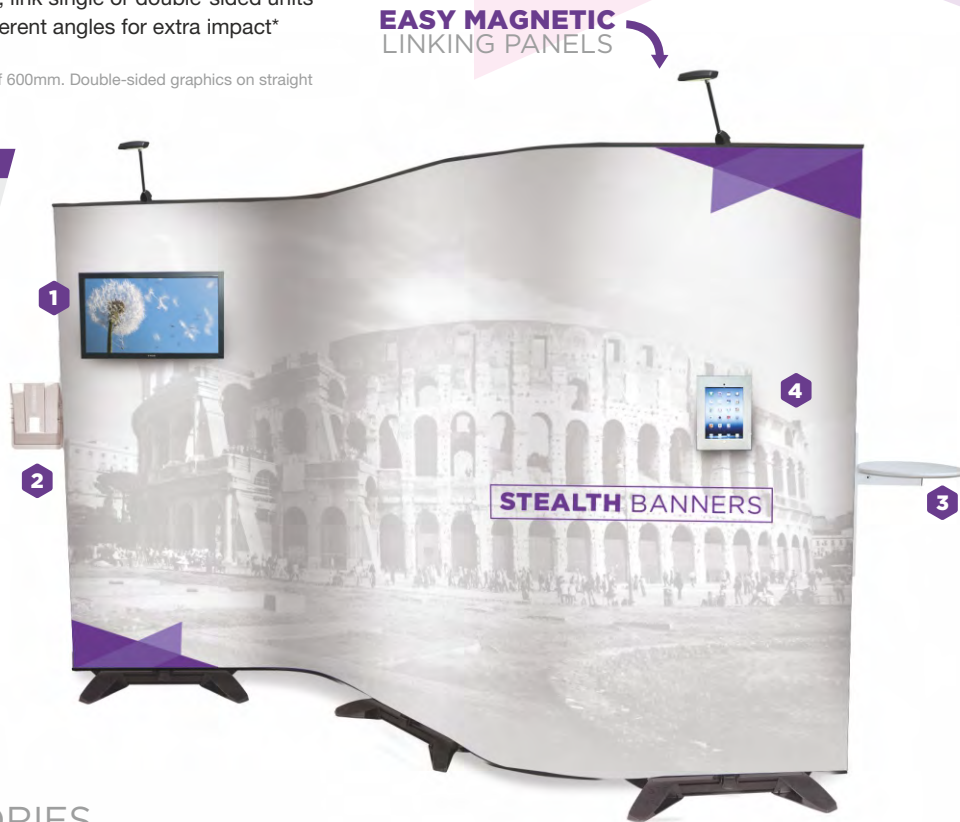

SA STEALTH ACCESSORIES

Add to your Stealth banner display with a range of stylish accessories to include Shelf, and Literature Holder, LCD bracket plus sturdy case that can be transformed into a counter with graphic wrap.



Optional case suitable for storing two Stealth units, a flexible joining panel and case graphic wrap.



Transport case: available options include case wrap and folding tabletop



1 LCD Bracket
LCD bracket is a specific design for use on Stealth - max. screen weight 5kg.



2 Acrylic Literature Holders
- DL LNST-DLP / DL LNST-A5P / DL LNST-A4P Easily fixed to your stand to advertise promotional material.



3 Tabletop - LNST-002
Attach a tabletop to the side of your banner.



4 iPad Holder - IPAD-HU-B/W/S
Available in black, white or silver. Ideal for placing centrally on graphic panel. iPad not included



New banner pole



Twist & lock pole

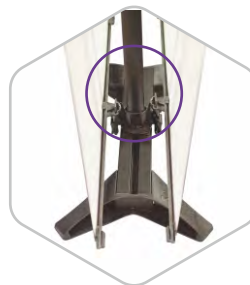

Tensioning system

STEALTH IMPROVEMENTS

At the base of each banner pole there is a unique sprung graphic fixing unit that features a tensioning system to ensure your graphics are held taut.

The unit has two sprung sections that work independently for individual tensioning of double-sided graphics.

Each post takes up to two universal LED light fittings to allow single or double-sided lighting. Recommended LED lighting - LED Flood Light and LED Strip Lights



LED Flood Strip Lights



STEALTH BANNER

Just a few ideas for inspiration, see how flexible Stealth is. Use single or double-sided graphics so your message can be seen from all angles.*

* Minimum panel width of 600mm. Double-sided graphics on straight configurations only



Flexible panels can curve to different angles.



Free-standing island displays and information units.



Portable road show displays or demonstrator back walls.



Banner-to-banner fixing for robust, perfectly straight back walls for events and exhibitions.



Create free-standing exhibition booths and sides. Large area backdrops for events and sponsorship.



Your image doesn't need to be flat. Create eye-catching curved displays.

SS SHELL SCHEME GRAPHICS

Exhibition and trade show shell-schemes are the most common spaces potential exhibitors will book when exhibiting at an event.

We have produced the simplest way to brand these shell-schemes by using PrintTac, Rollable tear resistant graphics, rigid foamex pvc graphics or vector frame with seamless fabric graphic. The graphic panels sit smoothly within the aluminium upright posts. We can even add the hook and loop velcro to your panels if required.

SP SHELL PRINTTAC SHELL SCHEME GRAPHICS

Simple, very cost-effective, very portable and very ecological.

Shell PrintTac is a made-to-measure, floor-to-ceiling graphic panel that sticks beautifully to your shell scheme panel and can be removed leaving NO residue. With care it can be used again on a variety of surfaces.

Each Shell PrintTac panel measures 950mm x 2340mm (standard size of a UK and Europe shell scheme panel)

- Leaves a visible shell scheme framework
- Simple fitting instructions are provided
- Made from an amazingly strong, fire-retardant, polyester blend
- Wont rip or wrinkle
- Good scratch and scuff resistance

SHELL PRINTTAC

Code: SPAC



VF VECTOR FRAME & BRACKETS WITH FABRIC GRAPHICS

We can produce stunning exhibition graphics to fit any shell scheme by using the Vector frame and brackets. This ensures the vector frame wall area provides a seamless fabric graphic wall.

VECTOR FRAME

Code: VFFG



RS RIGID SHELL SCHEME PANELS

We have a wide range of velcro friendly Rigid display panels. Our printed rigid display boards make the ideal trade show exhibit graphics. These Display Boards are a popular solution to branding exhibition and trade show stands. Large format high quality printing using vivid inks onto a 3mm foamex PVC board. You get a lightweight durable display board that can be screwed or attached using Velcro onto an exhibition booth.

RIGID SHELL

Code: RSSP





FABRIC TENSION SYSTEMS

The Fabric Tension family of products are built around an extensive collection of aluminium frame systems. Graphics are printed to your choice of fabrics from our range, to suit front or back lit use with outdoor and indoor options. Each fabric print is finished with a silicon welt which simply pushes into the frame profile creating a tensioned, fitting free finish installation and a 'frameless look'. Our fabric graphics systems enable you to put great artwork at the centre of your display.

- Stunning minimalist systems maximising graphics area with a 'frameless look'
- Easy user graphics change
- Stunning wide format fabric graphics
- Choice of profile depths
- LED Light box option available

DOUBLE SIDED VERTICAL CURVED FREESTANDING



DOUBLE SIDED ARCHWAY CURVES



DOUBLE SIDED CURVED FREESTANDING

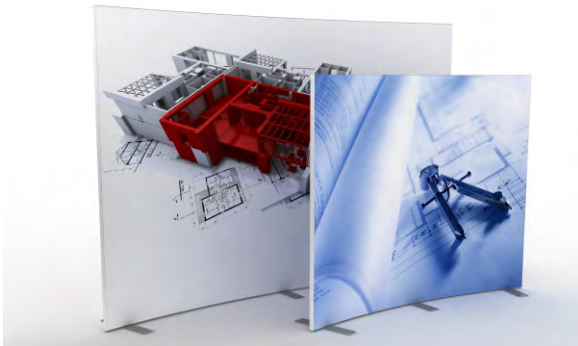

SINGLE SIDED LIGHTBOX FREESTANDING

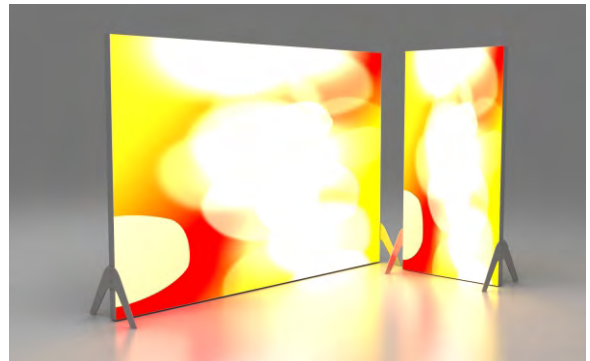

SINGLE SIDED LIGHTBOX WALL MOUNT

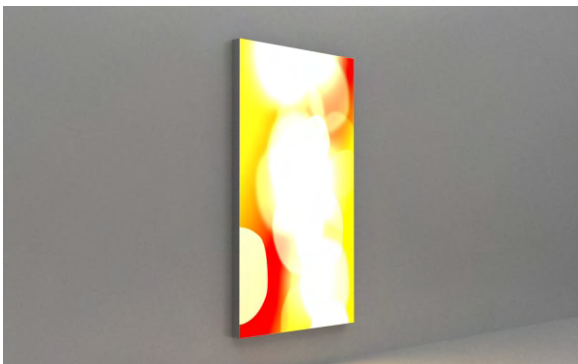

SINGLE SIDED WALL MOUNT

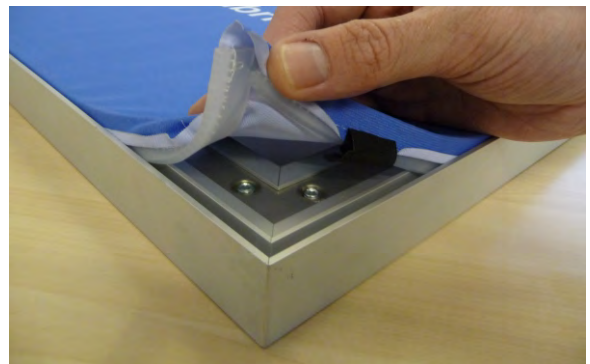

FC FABRIC "SUPER LIGHTWEIGHT" POP UP SYSTEM

This fabric pop up option is super lightweight and can be installed in just 1 minute. Graphics are produced on 250gsm stretch fabric and are printed in one piece.

Ideal when speed and weight are an issue. Available in various sizes. The graphic can be fully wrapped around the ends or made to just for the front face.

- Simple yet elegant looking
- Fabric fits smoothly across the
- Frame work and stays in place
- once the frame has been collapsed
- Available with graphics printed in one piece
- Super lightweight (easy to carry)
- Installs in less than one minute

FREE
WHEELED
CARRY
BAG

• Stand Size:

- 3x2 - 2262 (h) x 1525 (w) mm - Code: FPU3X2
- 3x3 - 2262 (h) x 2260 (w) mm - Code: FPU3X3
- 3x4 - 2262 (h) x 2995 (w) mm - Code: FPU3X4
- 3x5 - 2262 (h) x 3730 (w) mm - Code: FPU3X5



FH FABRIC HOP-UP COUNTER

Quick and easy to assemble with single wrap around fabric graphic. Tool free assembly. Single shelf and carry bag included.

- Visible graphic area (approx): 995 (h) x 1685 (w) mm
- Total hardware dimensions (approx):
- 1020mm (h) x 1065mm (w) x 400mm (d)
- Graphics are produced on Heavy Duty Fabric

FABRIC HOP-UP

Code: FHUC-01

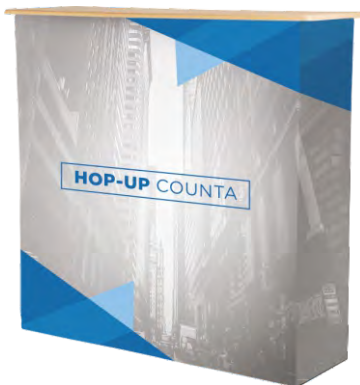

No graphic view



CP DESKTOP FLAGS

These desktop flags will look stunning on every desk or table.

- Printed double sided on polyester satin
- No minimum order

DESKTOP FLAG A

Code: DTF01

DESKTOP FLAG B

Code: DTF02





POP UP COUNTER

The versatile pop up counter is a great add-on to any existing display system. Graphics are produced on sturdy laminated material and are then magnetically attached around the front and sides of the podium concealing sturdy shelving.

- Elegant high quality, rapid erect, self supporting anodised aluminium structure
 - Simple fully magnetic rail connection
 - Laminated counter top, shelves, carry bag supplied
 - Footprint 1305mm x 505mm, height 906mm
- Visible graphic area (approx):
2x1: 950mm (h) x 1540mm (w)
2x2: 950mm (h) x 2060mm (w)
- Total hardware dimensions (approx):
2x1: 985mm (h) x 865mm (w) x 400mm (d)
2x2: 985mm (h) x 1290mm (w) x 465mm (d)

2x1	2x2
Code: PCS21	Code: PCS22



Reverse view



2x1 Pop-up Counter



OYSTER COUNTER

The Oyster case is a spacious sturdy 'clam style' transportation case which converts quickly into a stylish and surprisingly XL sized counter.

- Large wrap around table top and integral locking nuts to secure quickly into place
 - Two detachable shelves for storage
 - Design your own graphics on the wrap
 - Store your pop-up display, plus table top and shelves inside Oyster and wheel away
 - Graphic Wrap included
- Visible graphic area (approx):
920 (h) x 1745 (w) mm
- Total hardware dimensions (approx):
Open: 1020 (h) x 1430 (w) x 595 (d) mm
Closed: 1010 (h) x 660 (w) x 430 (d) mm

OYSTER
Code: OYSC-01



PC PODIUMS & COUNTERS

Constructed from composite materials and flexible MDF tambour finished in a choice of coloured fabric coverings. Transformed into sturdy constructed podiums load bearing up to 75kg. Easy to assemble without tools. All furniture tops and bases are constructed from thermoformed MDF in a choice of four finishes.



Hexagonal



Convex

SC COMET PODIUM

- Constructed from composite materials, flexible MDF tambour and Linear Aluminium profile pole
- Tops are available in Birch, Black, Silver or White thermoformed finishes
- Optional carry bag available

WITH GRAPHIC

Code: PK189

DP DOUBLE D PODIUM

- Constructed from composite materials
- Can be used as a full wrap or open back kneehole style unit Optional carry bag available
- Tops are available in Birch, Black, Silver or White thermoformed finishes

WITH FABRIC WRAP

Code: PK161

WITH GRAPHIC WRAP

Code: PT161

PC PROMO COUNTERS

- Portable flat-pack design – quick and easy to assemble
- Choice of two styles with white laminate or wood tops
- Panels suitable for vinyl application or direct-to-surface print

CONVEX

Code: CON004

HEXAGONAL

Code: HEX004



SC DISPLAY PLINTH

- Freestyle or Graphic options
- Tops are available in Birch, Black, Silver or White thermoformed finishes
- Smooth fabric wraps, Beech or Aluminium tambour wraps available at additional cost.

WITH GRAPHIC

Code: PK189P

CL CURVED LINEAR

- Top and base available in a choice of Birch, Black, Silver and White finishes
- Available in 30° and 45° radius sizes
- Very solid and durable
- Flat-pack for easy transportation
- Optional carry bag available

WITH GRAPHIC

Code: CLC169

VC V COUNTER

- Very robust
- Deluxe option includes integral shelf and lockable door
- Available in white, black, silver and birch finishes
- Sides available in silver or white

STANDARD

Code: VC179

WITH GRAPHIC

Code: VC180

TC PROMO TORNADO COUNTER

- Constructed from moulded HDPE and PVC tambour
- Moulded top with pen recess and water drainage notches
- Hollow base for water or sand weighting plus tambour wrap included
- Suitable for indoor and outdoor use
- Header and support poles optional extra
Includes printed graphics (header, front and side panels)

Total hardware dimensions (approx.):

- 1040 (h) x 850 (w) x 500 (d) mm
- PVC wrap: 900 (h) x 2070 (w) mm
- Header: 250 (h) x 600 (w) mm

WITH GRAPHICS & HEADER

Code: PTC01



PC PROMO COUNTER

- The Counta promota is supplied with a nylon carry bag
- Lightweight plastic flat pack promotional unit
- Suitable for indoor or outdoor use
- Includes rigid header panel, shelf and twin supporting poles
- Supplied with carry bag

Total hardware dimensions (approx.):

- Base: 860 (h) x 810 (w) x 478 (d) mm
- Header: 300 (h) x 780 (w) mm

COUNTER ONLY

Code: PCU-01

WITH GRAPHICS

Code: PCUG-01

(including header and front panel)

WITH GRAPHICS & HEADER

Code: PCUGS-01

(including header, front panel and sides)



SC SOLUS COUNTER

- Clever joining components are moulded from clear materials so as not to interfere with the graphic effect
- Solus can also be used as a double sided reusable easy to set up demonstration display centre for use in-store by a marketing presenter when used at 906mm high
- Optional opening one side for storage purposes

Maximum overall dimensions:

- 844(w) x 415(d) x 906mm(h)

COUNTER ONLY

Code: SCCO

WITH GRAPHICS

Code: SCG

CARRY BAG

Code: SCCB

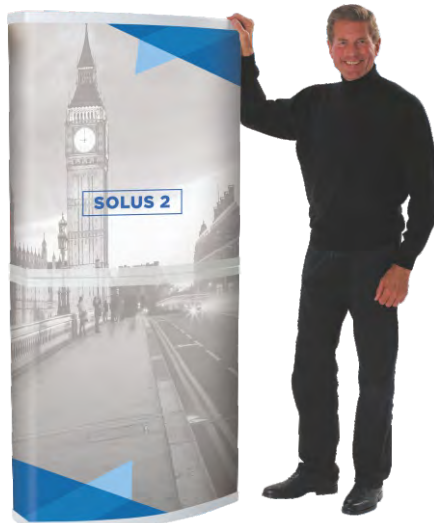

CP CHAMPION PROMOTER COUNTER

- Curved bar shaped, smooth, strong top
- Full size designed work surface 250mm below the top
- Additional shelf can be supplied providing extra storage space
- Body panel, like Classic Promotor, hinged in two segments
• which allows body panel to fold smaller than Promotor Plus

Maximum overall dimensions:

- 1240(w) x 375(d) x 2218mm(h)

COUNTER ONLY

Code: CPCO

WITH GRAPHICS

Code: CPCG

WITH GRAPHICS & HEADER

Code: CPCGH





VISION SITE MASTER A BOARD

- Silver anodised frames with rounded corners for safety
- Heavy duty springs allow panel deflection in the wind and so improve stability
- Double sided snap frames for quick and easy poster change
- Rigid “kick proof” back panel
- In built wheels for ease of movement
- Anti-glare PET poster covers
- Grey water fillable base with in built wheels and carry handle
- Trolley available -£POA
- Supplied with/without graphics

A2 Code: VSMA2	A1 Code: VSMA2
A0 Code: VSMA0	30"x40" Code: VSM3040

SUITABLE FOR RETAIL AND IDEAL FOR PAVEMENT ADVERTISING



SENTINEL A BOARD

- Smooth rounded corners for safety.
- Optional ‘Tactical Headers’.
- Zinc phosphate and polyester powder coated steel frame (50 x 25mm oval).
- Stainless steel tamper proof fixings retain poster cover at the top and enable ease of poster change by one person.
- Back panel available printed to ensure presence when posters are not in use.
- Clear polycarbonate poster covers offer high impact resistance and UV stability.
- Magnetic poster covers provide superior weather resistance and poster security.
- Water-fillable polyethylene base, precisely calculated for optimum stability, made using recycled materials.
- Black base as standard to hide dirt and marks – also available in custom colours (minimum order quantity 100).
- Built in wheels and purpose designed trolley, make it easy to move into position.
- Lower cost, lighter weight base option available for 30” x 40” and A0 sizes. Volume/contract enquiries only.
- Tactical Header also available, ideal for short term promotion. Giving additional advertising space for minimal cost.

A2 Code: SABA2	A1 Code: SABA1
A0 Code: SABA0	30"x40" Code: SAB3040



AA A MASTER A BOARD

- Available in many sizes
- Lightweight fold flat, front snap opening, silver anodised
- 32mm snapframes with rounded corners for safety
- Anti-glare poster covers to protect graphics
- Galvanised steel back panels and hinged locking
- arms for optimum weight and stability
- Black powder coated frame available in certain sizes £POA
- Also frame and legs available in any RAL colour
- Supplied with/without graphics

A2	A1	A0	20" x 30"
AMBA2	AMBA1	AMBA0	AMB203
500mm x 700mm	700mm x 1000mm	30" x 40"	
AMB500	AMB700	AMB304	



SA STANDARD A BOARD

- Available in many sizes
- Lightweight fold flat, front snap opening, silver anodised
- 32mm snapframes with rounded corners for safety
- Anti-glare poster covers to protect graphics
- Galvanised steel back panels and hinged locking arms
- for optimum weight and stability
- Black powder coated frame available in certain sizes £POA
- Also frame and legs available in any RAL colour
- Supplied with/without graphics

A2	A1	A0	20" x 30"
STABA2	STABA1	STABA0	STAB2030
500mm x 700mm	700mm x 1000mm	30" x 40"	
STAB500700	STAB7001000	STAB3040	



BA BOOSTER A BOARD

- Attractive poster A-board with semi-circular header for additional permanent graphic
- Double sided poster display
- Easy poster access via hidden release hole behind each panel
- Magnetic edged anti-glare PET poster covers provide excellent poster security and weather resistance
- Locking side arms for stability
- 25mm diameter steel tube frame
- Fully recyclable steel frames, steel back panels
- 3 stock colours available:
- A2 and A1 are available in black and white only
- Special colours also available (minimum order quantity 50)
- Supplied with/without graphics

A2	20" x 30"	A1
BAB01	BAB02	BAB03



BA BUDGET A BOARD

- Overall dimensions 500mm (w) x 830mm (h)
- Display area 480mm x 815mm
- Double sided display for permanent vinyl
- Suitable for sheltered locations only
- Recycled and recyclable polystyrene (HIPS) panels
- Approx 4kg
- Supplied with/without graphics

A2

Code: BAB-01



ES ECOFLEX STANDARD

- Permanent panel
- Display area 460mm (w) 783mm (h)
- Optional graphics printed on to 3 year vinyl and laminated
- Available with or without applied printed graphics
- Simplest "no tools" assembly - panel simply pushes into base and secured by single nylon fixing
- Rounded corners and smooth edges minimise health and safety concerns
- Rugged recycled (and recyclable)
- PVC base provides excellent stability
- In-built carry handle
- Approx 9kg
- Supplied with/without graphics

460MM X 783MM

Code: EFS-01

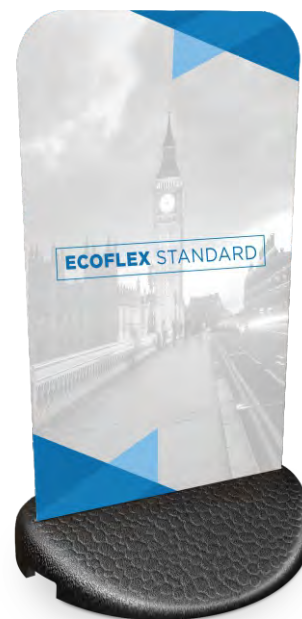

ES ECO SWINGER

- Permanent panel
- Display area 430mm (w) 625mm (h)
- Come complete with double sided digital printed panel
- Stylish 32mm round steel tube frame
- Frame available in black or white
- Solid black recycled PVC base
- Anti-shock 'D-flex' panel hangers handle
- Supplied with/without graphics

430MM x 625MM

Code: ES2W



SP SWINGER 3000 PANEL

- Designed so that adhesive vinyl can be applied to face
- Overall dimensions 668mm (w) x 1119mm (h)
- Graphics area 558mm (w) x 917mm (h)
- Stylish oval steel tube frame
- Water fillable base with in-built wheels allows ease of movement
- Black base as standard
- White or black panel/frame
- Optional graphics printed onto 3 year vinyl both sides
- Supplied with/without graphics

A2

Code: S3000P-01



SP SWINGER 3000 POSTER

- Easy interchangeable graphics from top
- Overall dimensions 668mm (w) x 1119mm (h)
- Poster size 20" (w) x 30" (h)
- Header panel area for permanent message (call for prices)
- New top opening poster pocket with magnetic seals provides excellent weather resistance and durability
- Stylish oval steel tube frame
- Available with or without posters
- White or black panel/frame
- Water fillable base with in-built wheels allows ease of movement
- Black base as standard
- Supplied with/without graphics

20" x 30"

Code: S3000P-02



SP SWINGER 4000 POSTER

- Easy interchangeable graphics
- Overall dimensions 774mm (w) x 1191mm (h)
- Poster size 594mm (w) x 841mm (h)
- Header panel area for permanent message (call for prices)
- New top opening poster pocket with magnetic seals provides excellent weather resistance and durability
- Stylish oval steel tube frame
- Available with or without posters
- White or black panel/frame
- Water fillable base with in-built wheels allows ease of movement
- Black base as standard
- Supplied with/without graphics

A1

Code: S4000P-03





ZL **ZED-UP LITE**
LITERATURE HOLDER

- High-tech shelving in A5, A4 and A3, anodised silver
- Complete with heavy duty hard case
- Double-sided acrylic shelves that fold down for easy transportation

Total hardware dimensions (approx.):
 Assembled:
 A3 - 1420 (h) x 470 (w) x 370 (d) mm
 A4 - 1460 (h) x 256 (w) x 370 (d) mm
 A5 - 1300 (h) x 194 (w) x 284 (d) mm
 Collapsed:
 A3 - 110 (h) x 471 (w) x 400 (d) mm
 A4 - 110 (h) x 256 (w) x 400 (d) mm
 A5 - 120 (h) x 206 (w) x 284 (d) mm



Carry case included



STRAIGHT A5

Code: ZUL-5

STRAIGHT A4

Code: ZUL-4

STRAIGHT A3

Code: ZUL-3

ZU ZED UP

- Highly functional, double-sided holder with six pockets
- Collapsible for easy transportation
- Available in A4

Total hardware dimensions (approx.):
Assembled: 1540 (h) x 275 (w) x 365 (d) mm
Collapsed: 195 (h) x 275 (w) x 365 (d) mm

ZED UP A4

Code: ZUS-4

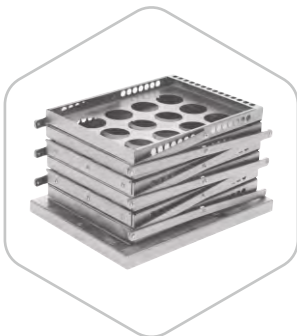

UD 10 UP DELUXE

- Neatly styled holder with ten A4 'wire' frame pockets and smart matt silver finish
- Breaks into three separate pieces
- for easier transportation
- Slim and lightweight

Total hardware dimensions (approx.):
1365 (h) x 300 (w) x 360 (d) mm

10 UP DELUXE

Code: DSL-04

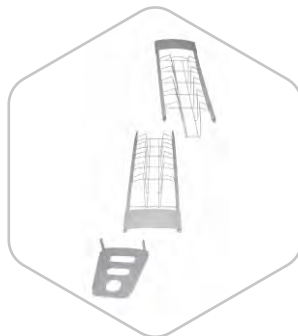

AS AURA STAND

- Versatile one-step cantilever literature stand, collapsible for easy transportation
- Four A4 pocket capacity with anti collapsible locking arm
- Attractive birch effect base, ideal for exhibition displays

Total hardware dimensions (approx.):
Assembled: 1400 (h) x 340 (w) x 310 (d) mm
Collapsed: 360 (h) x 340 (w) x 310 (d) mm

AURA STAND

Code: AIS-4



ZU ZED UP INJECTION MOULDED LITERATURE HOLDER

- Attractively designed collapsible double-sided folding literature holder
 - Three shelves each side
 - Lightweight and portable
 - Easy to put up and simple to use, ideal for exhibition environments
 - Supplied with premium bag
- Brochures can be stacked on shelves either side of literature holder - front or back!

ZED UP

Code: ZUPIA4

Total hardware dimensions (approx.):
Assembled: 1405(h) x 275 (w) x 390 (d) mm
Collapsed: 215 (h) x 275 (w) x 390 (d) mm



Collapsed unit

DOUBLE SIDED

PORTABLE,
LIGHTWEIGHT
AND EASY
TO USE



LM LINEAR MEDIA POSTS

Linear literature posts include a choice of audio, graphic and literature combinations to add to your stand.

LINEAR MEDIA

Code: LMP

Visual graphic area (approx.):
LK026-001 - 1800 (h) x 512.25 (w) mm
LK026-002 - n/a

Total hardware dimensions (approx.):
LK026-001
2060 (h) x 523 (w) x 450 (d) mm
LK026-002
1860 (h) x 595 (w) x 450 (d) mm

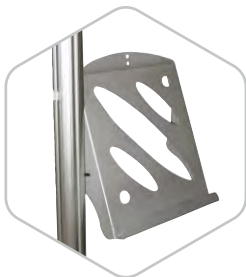

Steel literature holder

TV monitor not included



Graphic & literature post
LK026-001



Audio visual & literature post
LK026-002



FOLDING PANEL KITS

Our popular folding kits offer a choice of size, configuration and colour. Choose from a swatch of fabric colours and black or grey PVC frame. Receptive to Velcro Hook. (No suitable for pins).

- Double sided referable kit
- Rough lightweight baseline PVC frames in black or grey
- Fire rated fabric
- Choose from 15 loop nylon fabric colours
- No tools required
- Choose from 2 main panel sizes
- Header panel height 250mm (landscape)
- Includes FREE carry case



900x600mm



JUNIOR TABLE TOP FOLDING KIT
Code: JTK002



SENIOR TABLE TOP FOLDING KIT
Code: STK002



6 PANEL FOLDING KIT (HEADER)
900mm x 600mm Code: FK69
1000 x 700mm Code: FK100



7 PANEL FOLDING KIT (HEADER/TABLE)
900mm x 600mm Code: FK70
1000 x 700mm Code: FK107

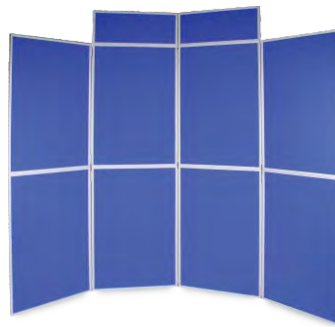

8 PANEL FOLDING KIT (HEADER/TABLE)
900mm x 600mm Code: FK80
1000 x 700mm Code: FK108



10 PANEL FOLDING KIT (2 HEADERS)
900mm x 600mm Code: FK10
1000 x 700mm Code: FK110

FOLDING KIT SWATCH



ST STRAIGHT TALKERS

Crystal clear acrylic menu displays for double-sided paper inserts

- Made in hard-wearing acrylic
- Incredibly quick and easy to remove and replace inserts
- For double-sided message display
- Presents and protects any paper insert

SIZE	O/A DIMENSIONS (W x H x D mm)	CODE
A6 Portrait	105 x 152 x 75	STRTA6P
1/3 A4 Portrait	105 x 212 x 75	STRT1/3A4P
A5 Portrait	150 x 212 x 75	STRTA5P
A4 Portrait	210 x 302 x 105	STRTA4P

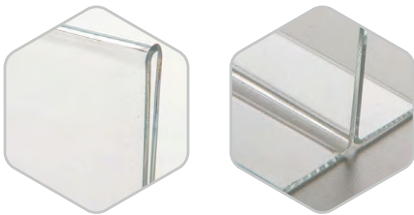

Other sizes available made to order: A4 landscape, A5 landscape, A6 landscape, 1/3 A4 landscape



TT TILT TALKERS

Angled menu displays for single-sided paper inserts

- Angle designed for optimum viewing from above
- Made in hard-wearing acrylic
- Quick and easy to remove and replace inserts
- For single-sided message display
- Presents and protects any paper insert

SIZE	O/A DIMENSIONS (W x H x D mm)	CODE
A6 Portrait	105 x 155 x 72	TILTA6P
1/3 A4 Portrait	105 x 215 x 72	TILT1/3A4P
A5 Portrait	150 x 215 x 72	TILTA5P
A4 Portrait	210 x 305 x 92	TILTA4P
A4 Portrait +front pocket	210 x 305 x 120	TILTA4PPF



A4 PORTRAIT
AVAILABLE WITH
BUSINESS CARD
HOLDER
(IN STOCK)

Other sizes available made to order: A4 landscape, A5 landscape, A6 landscape, 1/3 A4 landscape, A4 landscape with business cards





INTERIOR LEAFLET DISPENSERS

Crystal clear injection moulded styrene leaflet holders in a wide range of stock sizes.

- Great prices on mass produced lines – 1/3 A4, A5 and A4 single compartment dispensers
- Colours and branding available on volume orders (minimum order quantities apply – see below)
- Business card holders and other non-stock sizes available – please call for details



Dimensions: 95 x 55 x 39mm



DESCRIPTION	1/3 A4 FREE STANDING	A5 FREE STANDING	A4 FREE STANDING	1/3 A4 WALL MOUNTED	A5 WALL MOUNTED	A4 WALL MOUNTED
Opening Size (mm)	109x32	109x32	109x32	109x32	109x32	109x32
O/A Dimensions (mm)	111x198x83	111x198x83	111x198x83	111x198x83	111x198x83	111x198x83
Order Code	FS13A4	FS13A4	FS13A4	FS13A4	FS13A4	FS13A4

Single compartment leaflet dispensers available printed (minimum order quantity: 200)



MULTI COMPARTMENT LEAFLET DISPENSERS



DESCRIPTION	2x 1/3 A4 SIDE-BY-SIDE FREE STANDING	2x 1/3 A4 STACKED FREE STANDING	4x 1/3 A4 STACKED FREE STANDING	4x A4 STACKED FREE STANDING OR WALL*	4x COMPARTMENT A4 LANDSCAPE STACKED**
Opening Size (mm)	112x32 (x2)	110x42 (x2)	110x32 (x2)	230x32 (x4)	336x32 (x4)
O/A Dimensions (mm)	233x249x85	115x270x120	115x255x150	236x340x175	340x345x175
Order Code	SBS002	S13A4	S13A4A	S4A45	S4A4LS

Multi-compartment leaflet dispensers available printed (minimum order quantity: 100)

*Includes dividers for 8 x 1/3 A4 compartment option **Includes dividers for a combination of compartment sizes, freestanding or wall mounted



VECTOR WALL QUICK FIX

Linear Vector wall mounted frames are the easy way to create the perfect environment, whether it's a corporate or commercial interior or a retail display where you need to change your message frequently.

- Easily mounts straight onto walls by self drilling
- For use with lightweight dye-sublimated fabric graphics with silicone and beading (optional extra)
- Displays from 250mm up to size B0 (1000 x 1414 mm) and custom sizes are available on request



POSTER SIZE - (W) X (H) MM	CODE
A0 - 841mm x 1189mm	VWA0
A1 - 594mm x 841mm	VWA1
A2 - 420mm x 594mm	VWA2
B0 - 1000mm x 1414mm	VWB0
B1 - 707mm x 1000mm	VWB1

SQUARE SIZE - (W) X (H) MM	CODE
1000 x 1000	VW1000
250 x 250	VW250
500 x 500	VW500
750 x 750	VW750

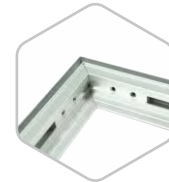

Self drill wall mounted



SNAP FRAMES

- Simple snap action suitable for substrates up to 0.5mm thick
- 25mm wide frame in aluminium with anodised silver finish
- Wall mounted, portrait or landscape with mitred corners



Custom colours and sizes available to order. Standard sizes available from stock

POSTER SIZE (W) X (H) MM	VISIBLE AREA (W) X (H) MM	EXTERNAL FRAME (W) X (H) MM	CODE
A0 - 841 x 1189	824 x 1172	872 x 1220	TFA0
A1 - 594 x 841	577 x 824	625 x 872	TFA1
A2 - 420 x 594	403 x 577	451 x 625	TFA2
A3 - 297 x 420	280 x 403	328 x 241	TFA3
A4 - 210 x 297	193 x 280	241 x 676	TFA4
B1 - 707 x 1000	690 x 983	676 x 969	TFB1
B2 - 500 x 707	483 x 690	469 x 676	TFB2



LED LIT SNAP FRAME

32mm wall frame with LED edge lit.

- Snap action frame for easy change graphics
- Available in six sizes from A0 to B1
- LED edge lit to all four sides creating exciting pictures

POSTER SIZE - (W) X (H) MM	CODE
A0 - 841mm x 1189mm	LLA0
A1 - 594mm x 841mm	LLA1
A2 - 420mm x 594mm	LLA2
B0 - 1000mm x 1414mm	LLB0
B1 - 707mm x 1000mm	LLB1

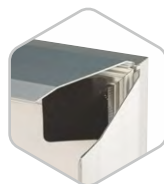

Corner fixing



SF SNAP FRAME FREESTANDING STANDS

Stylish single height freestanding poster frames which have adjustment for viewing angle and orientation.

Aluminium post combines with a sturdy steel base to provide stability. Available in A4 or A3, with satin anodised aluminium snap frames. Can be rotated to be used portrait or landscape.

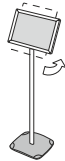

Size A4
H 297mm W 210mm
Height Port: 1010mm
Height Land: 967mm

Size A3
H 420mm W 297mm
Height Port: 1076mm
Height Land: 1014mm

A4

Code: SFFSA4

A3

Code: SFFSA3



TI TELESCOPIC INFORMATION STAND

Freestanding poster frame which is adjustable in height, angle and orientation. Telescopic aluminium post allows the frame to be height adjustable by 340mm. Available in A4 or A3, with satin anodised aluminium snap frames which can be rotated to be used portrait or landscape. Frames can also be viewed at any angle between horizontal and vertical. Sturdy steel base provides stability.

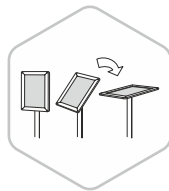

Frame can rotate between horizontal and vertical



Size A4
H 297mm W 210mm
Height Port: 910-1250mm
Height Land: 865-1205mm

Size A3
H 420mm W 297mm
Height Port: 970-1310mm
Height Land: 910-1250mm

A4

Code: TISA4

A3

Code: TISA3



SF SNAP FRAME FREESTANDING STANDS

Freestanding black poster stand. Attractive curved black stand holds A4 or A3 sized frames to display menus, sales literature or other information. The frame is mounted at the optimum viewing angle and able to be adjusted for horizontal or portrait orientation. The coated curved aluminium post is attached to a stable steel base.



Size A4
H 297mm W 210mm
Height Post: 1212mm
Height Land: 1176mm

A4
Code: SFA4



Size A3
H 420mm W 297mm
Height Post: 1262mm
Height Land: 1212mm

A3
Code: SFA3



BI BLACK ILLUMINATED POSTER STAND

LED edge lit acrylic poster stand in black. These striking curved black stands hold a A4 or A3 sized frame to illuminate menus, sales literature or other information. The frame is mounted at the optimum viewing angle and can be adjusted for horizontal or portrait orientation. The coated curved aluminium post is attached to a stable steel base. Integrated on-off switch at the rear of the unit. CE tested, comes complete with 3.5m cable and UK plug.



Size A4
H 297mm W 210mm
Height Post: 1250mm
Height Land: 1215mm

A4
Code: BISA4



Size A3
H 420mm W 297mm
Height Post: 1303mm
Height Land: 1250mm

A3
Code: BISA3





ALUMINIUM FRAMED MAGNETIC WHITEBOARD

Superior coated steel writing surface that also accepts magnets.

Excellent hardwearing surface for higher use applications. For use with drywipe pens. All boards 1800mm and over have extra central fixings for additional safety. Can be mounted landscape or portrait. Aluminium frame supplied with pen tray, concealed corner mounting and fixings. Surface guaranteed for 5 years.

SIZE	CODE
01 H 450mm x W 600mm	AFMW450
02 H 900mm x W 600mm	AFMW900
03 H 1200mm x W 900mm	AFMW1200A
04 H 1200mm x W 1200mm	AFMW1200B
05 H 1200mm x W 1500mm	AFMW1200D
06 H 1200mm x W 1800mm	AFMW1200E
07 H 1200mm x W 2400mm	AFMW1200F
08 H 1200mm x W 2700mm	AFMW1200G
09 H 1200mm x W 3000mm	AFMW1200H

**CUSTOM
PRINTING
AVAILABLE**

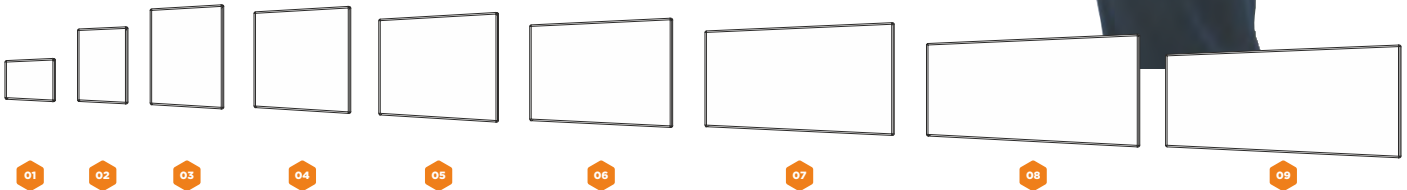

AF ALUMINIUM FRAMED FELT NOTICE BOARD

Best selling range of standard felt covered noticeboards with aluminium framing and round safety corners. Can be mounted portrait or landscape. Mounts through concealed corners, fixings supplied. Quality noticeboard in a choice of five felt colours for use with pins or Velcro®.

Standard felt cloth colours



SIZE	CODE
01 H 600mm x W 450mm	AFNB600
02 H 900mm x W 600mm	AFNB900
03 H 1200mm x W 900mm	AFNB1200
04 H 1200mm x W 1200mm	AFNB1200SQ
05 H 1200mm x W 1500mm	AFNB1500
06 H 1200mm x W 1800mm	AFNB1800
07 H 1200mm x W 2400mm	AFNB2400

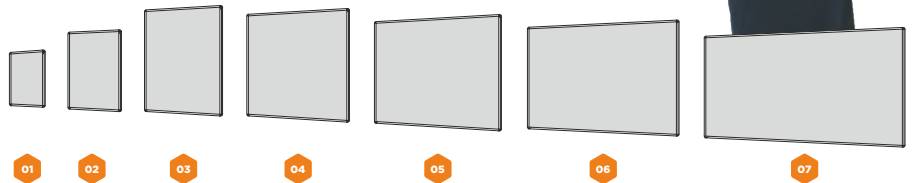

CUSTOM PRINTING AVAILABLE

AC ALUMINIUM FRAMED CORK NOTICE BOARD

A range of traditional cork surface noticeboards with aluminium framing and rounded safety corners.

Can be mounted portrait or landscape. Mounts through concealed corners, fixings supplied. Quality pinnable cork surface. Available in 7 popular sizes.

SIZE	CODE
01 H 600mm x W 450mm	AFCN600
02 H 900mm x W 600mm	AFCN900
03 H 1200mm x W 900mm	AFCN1200
04 H 1200mm x W 1200mm	AFCN1200SQ
05 H 1200mm x W 1500mm	AFCN1500
06 H 1200mm x W 1800mm	AFCN1800
07 H 1200mm x W 2400mm	AFCN2400

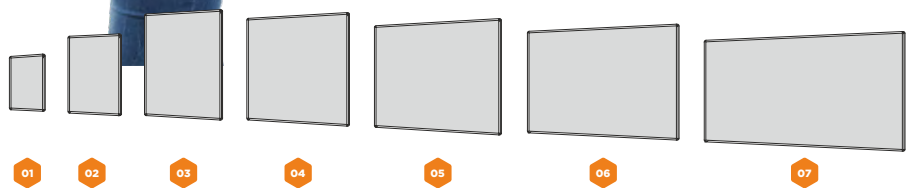

CUSTOM PRINTING AVAILABLE

MW MAGNETIC GLASS WHITEBOARDS

The ultimate in contemporary drywipe presentations.

The clean lines of this magnetic glass drywipe board is enhanced by the chrome mounts which float the board away from the wall. Available in a choice of 10 sizes from 500mm square up to 2.4 metres wide. The surface cleans easily with no ghosting. Made from toughened safety glass with a steel back. For use with super strength neodymium magnets. Optional matching glass pen tray available. All fixings included.



CUSTOM PRINTING AVAILABLE

SIZE	CODE
01 H 500mm x W 500mm	MGW500
02 H 600mm x W 450mm	MGW600
03 H 900mm x W 600mm	MGW900
04 H 1000mm x W 650mm	MGW1000A
05 H 1000mm x W 1500mm	MGW1000B
06 H 1000mm x W 2000mm	MGW1000C
07 H 1200mm x W 900mm	MGW1200A
08 H 1200mm x W 1200mm	MGW1200B
09 H 1200mm x W 1800mm	MGW1200C
10 H 1200mm x W 2400mm	MGW1200D

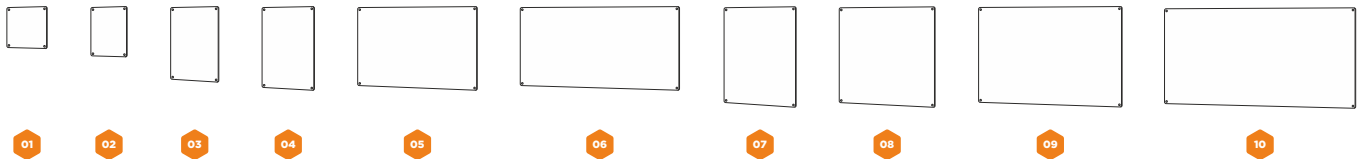

TL THEME BOARD LOCKABLE FRAME

Add your Club name, House or Department to these lockable covered noticeboards. New range of lockable noticeboards with a 200mm deep drywipe surface header. This tamperproof version has the added advantage of lockable doors to protect the information on display from casual interference.

Standard felt cloth colours Traditional cork



SIZE	CODE
01 H 600mm x W 450mm	TBLF600
02 H 900mm x W 600mm	TBLF900A
03 H 900mm x W 900mm	TBLF900B
04 H 1200mm x W 900mm	TBLF1200A
05 H 1200mm x W 1200mm	TBLF1200B
06 H 1200mm x W 1800mm	TBLF1200C

CUSTOM PRINTING AVAILABLE

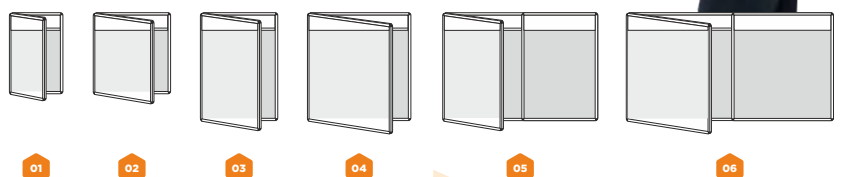

CI COLOURED GLASS INFORMATION BOARDS

Display your messages or menus in style.

A range of attractive glass dry-wipe boards which also accept super strength magnets. The glass board stands proud of the wall on special chrome fixings, supplied, adding to the visual impact. Made from 4mm toughened safety glass in a choice of 10 colours with a steel back. Ideal for restaurants, bars and reception areas.



White Black Red Blue Yellow Grey Violet Sky Blue Orange Lime

	SIZE	CODE
01	H 500mm x W 500mm	CGIB500
02	H 600mm x W 450mm	CGIB600
03	H 900mm x W 600mm	CGIB900
04	H 1000mm x W 650mm	CGIB1000

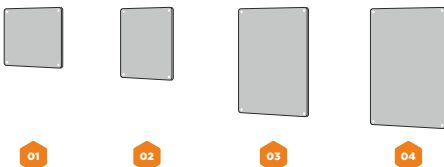

RW REVOLVING WHITEBOARDS

Versatile mobile whiteboard with dual action pivoting board. Enables both sides of the board to be used and angled towards your audience. Can be fixed during assembly to pivot either vertically or horizontally to suit your requirement. Available with drywipe steel surfaces to accept magnets or laminate surfaces, one plain and the reverse with a feint grid. Locking castors. Optional flip pad clips available.



	SIZE	LAMINATE	MAGNETIC
01	H 900mm x W 1200mm	RWL900	RWM900
02	H 1200mm x W 900mm	RWL1200A	RWM1200A
03	H 1200mm x W 1200mm	RWL1200B	RWM1200B
04	H 1200mm x W 1500mm	RWL1200C	RWM1200C
05	H 1200mm x W 1800mm	RWL1200D	RWM1200D



Drywipe Surface



Accepts Magnets



5cm Castors



Revolving

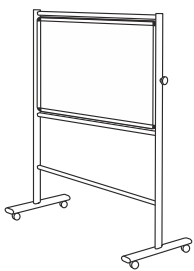

01

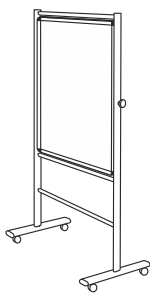

02

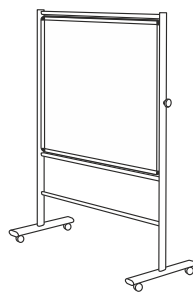

03

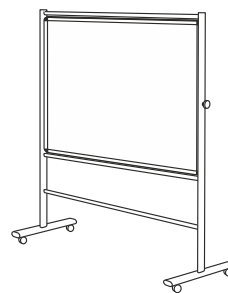

04

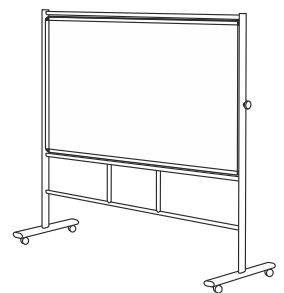

05

RW REVOLVING WHITEBOARDS

Double sided whiteboard that can pivot on its horizontal axis. Enables both sides to be used, or the surface angled towards the audience. Available with coated steel writing surface that has the advantage of accepting magnets, or non-magnetic surface that is one side plain, one side gridded. Sturdy steel frame has 4 castors, 2 of which are locking. Steel cross bars aid rigidity and house the supplied pen tray.



	SIZE	LAMINATE	MAGNETIC
01	H 900mm x W 1200mm	RWL900	RWM900
02	H 1200mm x W 900mm	RWL1200A	RWM1200A
03	H 1200mm x W 1200mm	RWL1200B	RWM1200B
04	H 1200mm x W 1500mm	RWL1200C	RWM1200C
05	H 1200mm x W 1800mm	RWL1200D	RWM1200D

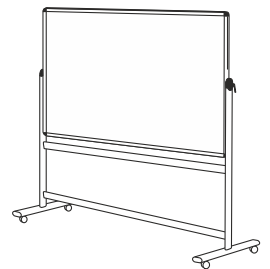
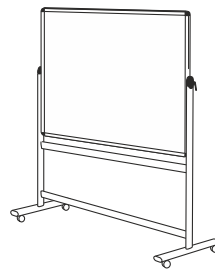
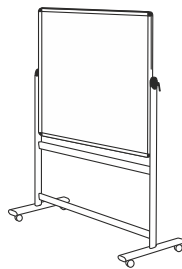
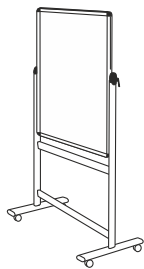
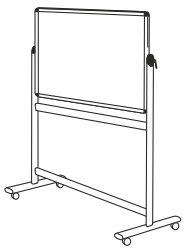

Sturdy locking wheels



Positive tilt locking lever



Full width pen tray

FE FLIPCHART EASELS

An entry level tripod easel but with the features of a more expensive model. Aluminium frame with steel drywipe surface to accept magnets. Adjustable flip pad holders. Rear leg has a brace for increased stability. Supplied with clip-on pen tray.



Flipchart easel



Clip on pad clamp



Pen tray



Leg brace for stability

CUSTOM PRINTING AVAILABLE



BOARD SIZE	CODE
H 1000mm x W 680mm	FE1000



Drywipe Surface



Accepts Magnets



Weight Cygnet 8kg



Stackable Vertical



Height Adjustable

UF ULTIMATE LOOP LEG FLIPCHART EASEL

Top selling colour framed easel - now in 6 colours. Loop leg design creates very steady base and foot bar aids stability when writing. Double sided magnetic whiteboard can be angled flat to aid pad preparation and is fully height adjustable. Available framed in a choice of 6 colours. Suitable for A1 standard 2 hole drilled pads. Optional carry bag.



Blue Red Green Black Grey White



Optional carrying bag



Tilts for preparation

BOARD SIZE	COLOUR	CODE
H 860mm x W 650mm	Blue	ULL860B
H 860mm x W 650mm	Red	ULL860R
H 860mm x W 650mm	Green	ULL860G
H 860mm x W 650mm	Black	ULL860K
H 860mm x W 650mm	Grey	ULL860E
H 860mm x W 650mm	White	ULL860W
H 860mm x W 650mm	Carry bag	ULL860C





LAPTOP WHITEBOARDS

Hand held whiteboards for classroom use.

Double sided whiteboards with Guideline® gridded surface one side and plain surface on the reverse. Smooth radiused corners for safety. Conveniently supplied in packs of six A4 and A3 boards

SIZE	CODE
A4 H 210mm x W 297mm	LWBA4
A3 H 297mm x W 420mm	LWBA3



LAPTOP WHITEBOARDS

Brightly coloured magnetic whiteboards.

Double sided drywipe whiteboards that have the benefit of also accepting magnets. The chunky multi-coloured ergonomic frame with rounded corner caps makes the board comfortable and safe to use.

SIZE	CODE
A4 H 210mm x W 297mm	CLWBA4



SF SELFIE FRAMES

- Printed: Single sided using the latest UV technology, bringing your images to life with great colour vibrancy.
- Sizes available: A2, A0 and A1.
- Printed direct onto 5mm Foamex board which is rigid and durable whilst still being lightweight and flexible.
- Suitable: For both indoor or outdoor use.

A2
Code: SFA2
A1
Code: SFA1
A0
Code: SFA0

**BESPOKE
CUT TO
SHAPE
AVAILABLE**

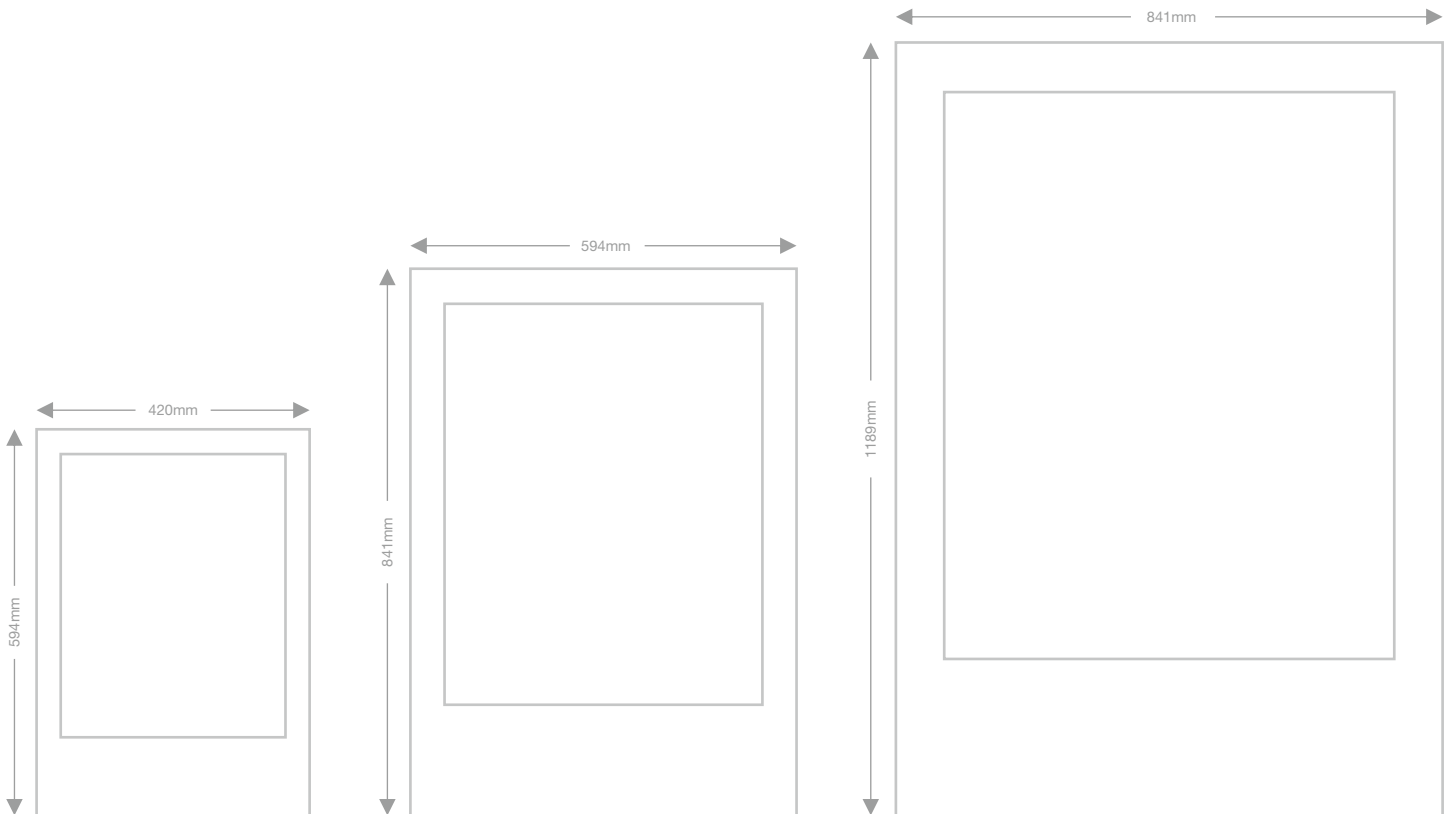

ML MATT LAMINATED BUSINESS CARDS

- Printed on 400gsm silk board
- 4 Working day service
- 85mm x 55mm

SINGLE SIDED	CODE	DOUBLE SIDED	CODE
250	MLS250	250	MLD250
500	MLS500	500	MLD500
1000	MLS1000	1000	MLD1000
2000	MLS2000	2000	MLD2000



SB STANDARD BUSINESS CARDS

- Printed on 400gsm silk board
- 4 Working day service
- 85mm x 55mm

SINGLE SIDED	CODE	DOUBLE SIDED	CODE
250	SS250	250	SD250
500	SS500	500	SD500
1000	SS1000	1000	SD1000
2000	SS2000	2000	SD2000



ST SOFT TOUCH LAMINATED BUSINESS CARDS

- Printed on 400gsm silk board
- 4 Working day service
- 85mm x 55mm

SINGLE SIDED	CODE	DOUBLE SIDED	CODE
250	STS250	250	STD250
500	STS500	500	STD500
1000	STS1000	1000	STD1000
2000	STS2000	2000	STD2000





A6 A6 FLYERS 130GSM

- Printed on 130gsm gloss paper
- 4 Working day service
- 105mm x 148mm



SINGLE SIDED	CODE	DOUBLE SIDED	CODE
500	A61305S	500	A61305D
1000	A61301S	1000	A61301D
2000	A61302S	2000	A61302D
5000	A613050S	5000	A613050D

A6 A6 FLYERS 170GSM

- Printed on 170gsm gloss paper
- 4 Working day service
- 105mm x 148mm



SINGLE SIDED	CODE	DOUBLE SIDED	CODE
500	A61705S	500	A61705D
1000	A61701S	1000	A61701D
2000	A61702S	2000	A61702D
5000	A61705S	5000	A61705D

DL DL FLYERS 130GSM

- Printed on 130gsm gloss paper
- 4 Working day service
- 99mm x 210mm



SINGLE SIDED	CODE	DOUBLE SIDED	CODE
500	DL1305S	500	DL1305D
1000	DL1301S	1000	DL1301D
2000	DL1302S	2000	DL1302D
5000	DL13050S	5000	DL13050D

DL DL FLYERS 170GSM

- Printed on 170gsm gloss paper
- 4 Working day service
- 99mm x 210mm



SINGLE SIDED	CODE	DOUBLE SIDED	CODE
500	DL1705S	500	DL1705D
1000	DL1701S	1000	DL1701D
2000	DL1702S	2000	DL1702D
5000	DL17050S	5000	DL17050D



A5 A5 FLYERS 130GSM

- Printed on 130gsm gloss paper
- 4 Working day service
- 148mm x 210mm



SINGLE SIDED	CODE	DOUBLE SIDED	CODE
500	A51305S	500	A51305D
1000	A51301S	1000	A51301D
2000	A51302S	2000	A51302D
5000	A513050S	5000	A513050D

A5 A5 FLYERS 170GSM

- Printed on 170gsm gloss paper
- 4 Working day service
- 148mm x 210mm



SINGLE SIDED	CODE	DOUBLE SIDED	CODE
500	A51705S	500	A51705D
1000	A51701S	1000	A51701D
2000	A51702S	2000	A51702D
5000	A517050S	5000	A517050D

A4 A4 FLYERS 130GSM

- Printed on 130gsm gloss paper
- 4 Working day service
- 210mm x 297mm



SINGLE SIDED	CODE	DOUBLE SIDED	CODE
500	A41305S	500	A41305D
1000	A41301S	1000	A41301D
2000	A41302S	2000	A41302D
5000	A413050S	5000	A413050D

A4 A4 FLYERS 170GSM

- Printed on 170gsm gloss paper
- 4 Working day service
- 210mm x 297mm



SINGLE SIDED	CODE	DOUBLE SIDED	CODE
500	A41705S	500	A41705D
1000	A41701S	1000	A41701D
2000	A41702S	2000	A41702D
5000	A417050S	5000	A417050D

PB PRINTED BROCHURES

We specialise in producing full colour brochures for all business promotions and advertising purposes.

- Printed on 130gsm gloss
- 7 Working day service
- 170gsm available £POA
- Heavy cover available £POA

DOUBLE SIDED	CODE
8pp Brochures	8PP130
12pp Brochures	12PP130
16pp Brochures	16PP130
20pp Brochures	20PP130



A4 A4 LETTERHEADS

- Printed on 120gsm bond paper
- 4 Working day service
- 210mm x 297mm

SINGLE SIDED	CODE	DOUBLE SIDED	CODE
250	A4SS250	250	A4DS250
500	A4SS500	500	A4DS500
1000	A4SS1000	1000	A4DS1000
2000	A4SS2000	2000	A4DS2000

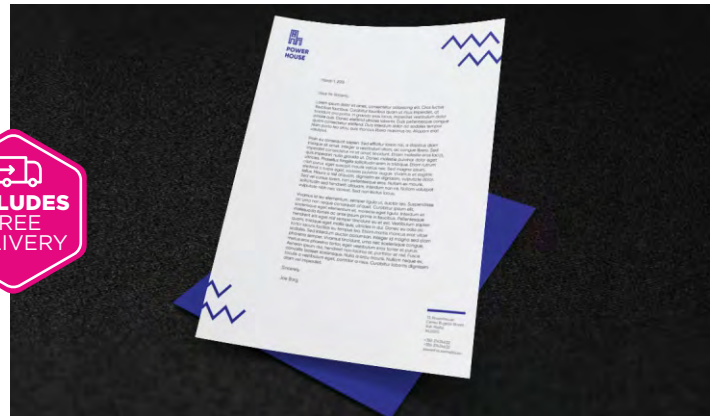

SP STATIONERY PACK

- Business cards, letter heads and compliment slips
- Letterheads/comp slips printed on 120gsm bond paper (single sided)
- Business cards printed on 400gsm silk board (single or double sided)
- Business cards matt laminated both sides
- 4 Working day service

SINGLE SIDED	CODE	DOUBLE SIDED	CODE
250	SPSS250	250	SPDS250
500	SPSS500	500	SPDS500
1000	SPSS1000	1000	SPDS1000
2000	SPSS2000	2000	SPDS2000



PF PRESENTATION FOLDERS

We produce a wide range of presentation folders which are ideal for displaying sales literature, promoting products and service and for use in seminars and training events. For the ultimate presentation document choose full colour print.

Have unlimited design potential and upgrade your order to incorporate anything from single to full colour reverse printing, standard or bespoke die cutting and UV varnish finishing.

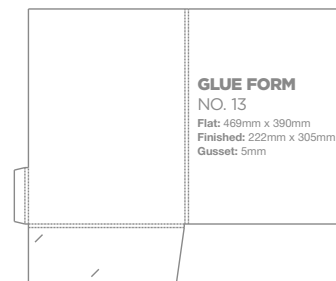
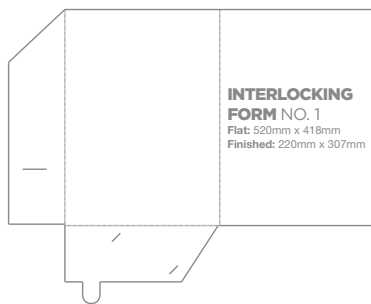

SB A4 INTERLOCKING FOLDERS

- Printed on 350gsm silk card
- No glue required
- Supplied flat, die cut and creased
- 7 Working day service



SINGLE SIDED	CODE	DOUBLE SIDED	CODE
250	PFSS250	250	PFDS250
500	PFSS500	500	PFDS500
1000	PFSS1000	1000	PFDS1000

SB A4 GLUED FOLDERS

- Printed on 350gsm silk card
- 5mm Gusset with glued up form
- Supplied made up
- 7/10 Working day service



SINGLE SIDED	CODE	DOUBLE SIDED	CODE
250	PFGSS250	250	PFGDS250
500	PFGSS500	500	PFGDS500
1000	PFGSS1000	1000	PFGDS1000



BESPOKE SIZES AVAILABLE

A2 A2 POSTERS

- Printed on 200gsm poster paper
- Printed using solvent inks
- 420mm x 594mm

A2 POSTER	CODE
1	A22001
2 - 5	A22005
6 - 10	A220010
11 - 25	A220025
26 - 50	A220050

PP 20" x 30" POSTERS

- Printed on 200gsm poster paper
- Printed using solvent inks
- 508mm x 762mm

20" x 30" POSTER	CODE
1	232001
2 - 5	232005
6 - 10	2320010
11 - 25	2320025
26 - 50	2320050

A1 A1 POSTERS

- Printed on 200gsm poster paper
- Printed using solvent inks
- 594mm x 841mm

A1 POSTER	CODE
1	A12001
2 - 5	A12005
6 - 10	A120010
11 - 25	A120025
26 - 50	A120050

A0 A0 POSTERS

- Printed on 200gsm poster paper
- Printed using solvent inks
- 594mm x 841mm

A0 POSTER	CODE
1	A02001
2 - 5	A02005
6 - 10	A020010
11 - 25	A020025
26 - 50	A020050



LIFE SIZE CARDBOARD CUTOUTS

Our life size cardboard cut outs are guaranteed to raise interest at conferences, events, exhibitions and parties. We can make life size cardboard cut outs from your own photograph and can even add speech bubbles, text etc to the design.

Please ask our sales team for further details.



CUSTOM POS (POINT OF SALE) DISPLAYS AND CARDBOARD CUBES

POS or Point of Sale stands are designed to promote brands and increase purchases, our displays are designed totally bespoke for you, by our expert in-house design team.

If you are looking for a stand to display your products, see FSDU (Free Standing Display Units) or CDU (Counter Display Units) Our point of sale display range includes pop-up display stands, POS window displays, cardboard cubes, cardboard totem displays, point of purchase displays, and much more, each eye-catching display is custom-made for you.





CONCEPT

'THE CORE COLLECTION'
Display Solutions